



78XX

3-Terminal 1A Positive Voltage Regulator

Features

- Output Current up to 1A
- Output Voltages of 5, 6, 8, 9, 10, 12, 15, 18, 24
- Thermal Overload Protection
- Short Circuit Protection
- Output Transistor Safe Operating Area Protection

General Description

The LM78XX series of three terminal positive regulators are available in the TO-220 package and with several fixed output voltages, making them useful in a wide range of applications. Each type employs internal current limiting, thermal shut down and safe operating area protection, making it essentially indestructible. If adequate heat sinking is provided, they can deliver over 1A output current. Although designed primarily as fixed voltage regulators, these devices can be used with external components to obtain adjustable voltages and currents.

Ordering Information

Product Number	Output Voltage Tolerance	Package	Operating Temperature	
LM7805CT	±4%	TO-220	-40°C to +125°C	
LM7806CT				
LM7808CT				
LM7809CT				
LM7810CT				
LM7812CT				
LM7815CT				
LM7818CT				
LM7824CT				
LM7805ACT	±2%		TO-220	0°C to +125°C
LM7806ACT				
LM7808ACT				
LM7809ACT				
LM7810ACT				
LM7812ACT				
LM7815ACT				
LM7818ACT				
LM7824ACT				

Block Diagram

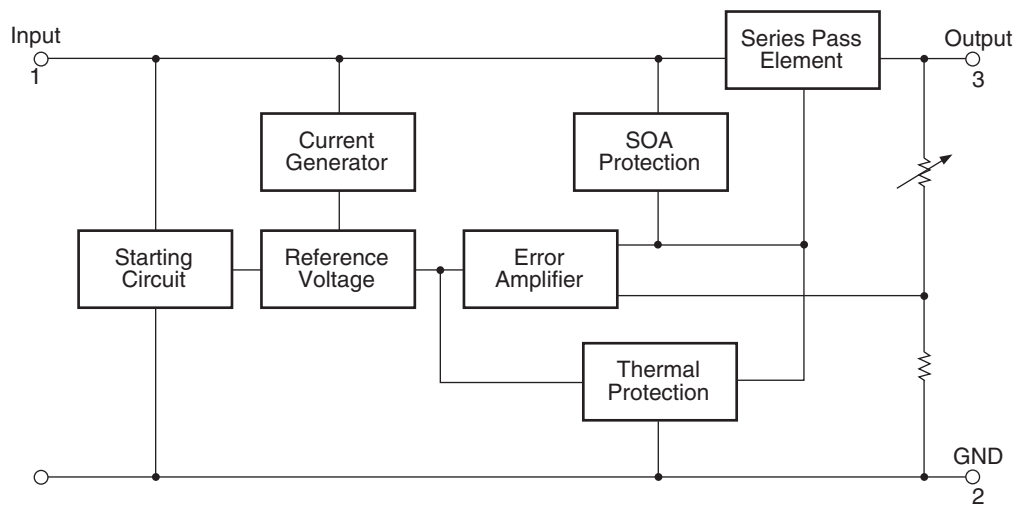

Figure 1.

Pin Assignment

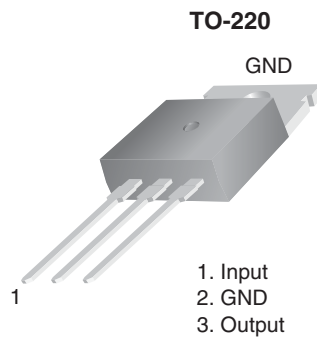

Figure 2.

Absolute Maximum Ratings

Absolute maximum ratings are those values beyond which damage to the device may occur. The datasheet specifications should be met, without exception, to ensure that the system design is reliable over its power supply, temperature, and output/input loading variables. Fairchild does not recommend operation outside datasheet specifications.

Symbol	Parameter	Value	Unit	
V_I	Input Voltage	$V_O = 5V$ to $18V$	35	V
		$V_O = 24V$	40	V
$R_{\theta JC}$	Thermal Resistance Junction-Cases (TO-220)	5	$^{\circ}C/W$	
$R_{\theta JA}$	Thermal Resistance Junction-Air (TO-220)	65	$^{\circ}C/W$	
T_{OPR}	Operating Temperature Range	LM78xx	-40 to +125	$^{\circ}C$
		LM78xxA	0 to +125	
T_{STG}	Storage Temperature Range	-65 to +150	$^{\circ}C$	

Electrical Characteristics (LM7805)

Refer to the test circuits. $-40^{\circ}\text{C} < T_J < 125^{\circ}\text{C}$, $I_O = 500\text{mA}$, $V_I = 10\text{V}$, $C_I = 0.1\mu\text{F}$, unless otherwise specified.

Symbol	Parameter	Conditions	Min.	Typ.	Max.	Unit	
V_O	Output Voltage	$T_J = +25^{\circ}\text{C}$	4.8	5.0	5.2	V	
		$5\text{mA} \leq I_O \leq 1\text{A}$, $P_O \leq 15\text{W}$, $V_I = 7\text{V to } 20\text{V}$	4.75	5.0	5.25		
Regline	Line Regulation ⁽¹⁾	$T_J = +25^{\circ}\text{C}$	$V_O = 7\text{V to } 25\text{V}$	–	4.0	100	mV
			$V_I = 8\text{V to } 12\text{V}$	–	1.6	50.0	
Regload	Load Regulation ⁽¹⁾	$T_J = +25^{\circ}\text{C}$	$I_O = 5\text{mA to } 1.5\text{A}$	–	9.0	100	mV
			$I_O = 250\text{mA to } 750\text{mA}$	–	4.0	50.0	
I_Q	Quiescent Current	$T_J = +25^{\circ}\text{C}$	–	5.0	8.0	mA	
ΔI_Q	Quiescent Current Change	$I_O = 5\text{mA to } 1\text{A}$	–	0.03	0.5	mA	
		$V_I = 7\text{V to } 25\text{V}$	–	0.3	1.3		
$\Delta V_O/\Delta T$	Output Voltage Drift ⁽²⁾	$I_O = 5\text{mA}$	–	-0.8	–	mV/ $^{\circ}\text{C}$	
V_N	Output Noise Voltage	$f = 10\text{Hz to } 100\text{kHz}$, $T_A = +25^{\circ}\text{C}$	–	42.0	–	$\mu\text{V}/V_O$	
RR	Ripple Rejection ⁽²⁾	$f = 120\text{Hz}$, $V_O = 8\text{V to } 18\text{V}$	62.0	73.0	–	dB	
V_{DROPP}	Dropout Voltage	$I_O = 1\text{A}$, $T_J = +25^{\circ}\text{C}$	–	2.0	–	V	
r_O	Output Resistance ⁽²⁾	$f = 1\text{kHz}$	–	15.0	–	$\text{m}\Omega$	
I_{SC}	Short Circuit Current	$V_I = 35\text{V}$, $T_A = +25^{\circ}\text{C}$	–	230	–	mA	
I_{PK}	Peak Current ⁽²⁾	$T_J = +25^{\circ}\text{C}$	–	2.2	–	A	

Notes:

1. Load and line regulation are specified at constant junction temperature. Changes in V_O due to heating effects must be taken into account separately. Pulse testing with low duty is used.
2. These parameters, although guaranteed, are not 100% tested in production.

Electrical Characteristics (LM7806) (Continued)

Refer to the test circuits. $-40^{\circ}\text{C} < T_J < 125^{\circ}\text{C}$, $I_O = 500\text{mA}$, $V_I = 11\text{V}$, $C_1 = 0.33\mu\text{F}$, $C_O = 0.1\mu\text{F}$, unless otherwise specified.

Symbol	Parameter	Conditions	Min	Typ.	Max.	Unit	
V_O	Output Voltage	$T_J = +25^{\circ}\text{C}$	5.75	6.0	6.25	V	
		$5\text{mA} \leq I_O \leq 1\text{A}$, $P_O \leq 15\text{W}$, $V_I = 8.0\text{V to } 21\text{V}$	5.7	6.0	6.3		
Regline	Line Regulation ⁽³⁾	$T_J = +25^{\circ}\text{C}$	$V_I = 8\text{V to } 25\text{V}$	–	5.0	120	mV
			$V_I = 9\text{V to } 13\text{V}$	–	1.5	60.0	
Regload	Load Regulation ⁽³⁾	$T_J = +25^{\circ}\text{C}$	$I_O = 5\text{mA to } 1.5\text{A}$	–	9.0	120	mV
			$I_O = 250\text{mA to } 750\text{mA}$	–	3.0	60.0	
I_Q	Quiescent Current	$T_J = +25^{\circ}\text{C}$	–	5.0	8.0	mA	
ΔI_Q	Quiescent Current Change	$I_O = 5\text{mA to } 1\text{A}$	–	–	0.5	mA	
		$V_I = 8\text{V to } 25\text{V}$	–	–	1.3		
$\Delta V_O/\Delta T$	Output Voltage Drift ⁽⁴⁾	$I_O = 5\text{mA}$	–	-0.8	–	mV/ $^{\circ}\text{C}$	
V_N	Output Noise Voltage	$f = 10\text{Hz to } 100\text{kHz}$, $T_A = +25^{\circ}\text{C}$	–	45.0	–	$\mu\text{V}/V_O$	
RR	Ripple Rejection ⁽⁴⁾	$f = 120\text{Hz}$, $V_O = 8\text{V to } 18\text{V}$	62.0	73.0	–	dB	
V_{DROP}	Dropout Voltage	$I_O = 1\text{A}$, $T_J = +25^{\circ}\text{C}$	–	2.0	–	V	
r_O	Output Resistance ⁽⁴⁾	$f = 1\text{kHz}$	–	19.0	–	m Ω	
I_{SC}	Short Circuit Current	$V_I = 35\text{V}$, $T_A = +25^{\circ}\text{C}$	–	250	–	mA	
I_{PK}	Peak Current ⁽⁴⁾	$T_J = +25^{\circ}\text{C}$	–	2.2	–	A	

Notes:

- Load and line regulation are specified at constant junction temperature. Changes in V_O due to heating effects must be taken into account separately. Pulse testing with low duty is used.
- These parameters, although guaranteed, are not 100% tested in production.

Electrical Characteristics (LM7808) (Continued)

Refer to the test circuits. $-40^{\circ}\text{C} < T_J < 125^{\circ}\text{C}$, $I_O = 500\text{mA}$, $V_I = 14\text{V}$, $C_1 = 0.33\mu\text{F}$, $C_O = 0.1\mu\text{F}$, unless otherwise specified.

Symbol	Parameter	Conditions	Min.	Typ.	Max.	Unit	
V_O	Output Voltage	$T_J = +25^{\circ}\text{C}$	7.7	8.0	8.3	V	
		$5\text{mA} \leq I_O \leq 1\text{A}$, $P_O \leq 15\text{W}$, $V_I = 10.5\text{V to } 23\text{V}$	7.6	8.0	8.4		
Regline	Line Regulation ⁽⁵⁾	$T_J = +25^{\circ}\text{C}$	$V_I = 10.5\text{V to } 25\text{V}$	–	5.0	160	mV
			$V_I = 11.5\text{V to } 17\text{V}$	–	2.0	80.0	
Regload	Load Regulation ⁽⁵⁾	$T_J = +25^{\circ}\text{C}$	$I_O = 5\text{mA to } 1.5\text{A}$	–	10.0	160	mV
			$I_O = 250\text{mA to } 750\text{mA}$	–	5.0	80.0	
I_Q	Quiescent Current	$T_J = +25^{\circ}\text{C}$	–	5.0	8.0	mA	
ΔI_Q	Quiescent Current Change	$I_O = 5\text{mA to } 1\text{A}$	–	0.05	0.5	mA	
		$V_I = 10.5\text{V to } 25\text{V}$	–	0.5	1.0		
$\Delta V_O/\Delta T$	Output Voltage Drift ⁽⁶⁾	$I_O = 5\text{mA}$	–	-0.8	–	mV/ $^{\circ}\text{C}$	
V_N	Output Noise Voltage	$f = 10\text{Hz to } 100\text{kHz}$, $T_A = +25^{\circ}\text{C}$	–	52.0	–	$\mu\text{V}/V_O$	
RR	Ripple Rejection ⁽⁶⁾	$f = 120\text{Hz}$, $V_O = 11.5\text{V to } 21.5\text{V}$	56.0	73.0	–	dB	
V_{DROP}	Dropout Voltage	$I_O = 1\text{A}$, $T_J = +25^{\circ}\text{C}$	–	2.0	–	V	
r_O	Output Resistance ⁽⁶⁾	$f = 1\text{kHz}$	–	17.0	–	m Ω	
I_{SC}	Short Circuit Current	$V_I = 35\text{V}$, $T_A = +25^{\circ}\text{C}$	–	230	–	mA	
I_{PK}	Peak Current ⁽⁶⁾	$T_J = +25^{\circ}\text{C}$	–	2.2	–	A	

Notes:

- Load and line regulation are specified at constant junction temperature. Changes in V_O due to heating effects must be taken into account separately. Pulse testing with low duty is used.
- These parameters, although guaranteed, are not 100% tested in production.

Electrical Characteristics (LM7809) (Continued)

Refer to the test circuits. $-40^{\circ}\text{C} < T_J < 125^{\circ}\text{C}$, $I_O = 500\text{mA}$, $V_I = 15\text{V}$, $C_I = 0.33\mu\text{F}$, $C_O = 0.1\mu\text{F}$, unless otherwise specified.

Symbol	Parameter	Conditions	Min.	Typ.	Max.	Unit	
V_O	Output Voltage	$T_J = +25^{\circ}\text{C}$	8.65	9.0	9.35	V	
		$5\text{mA} \leq I_O \leq 1\text{A}$, $P_O \leq 15\text{W}$, $V_I = 11.5\text{V to } 24\text{V}$	8.6	9.0	9.4		
Regline	Line Regulation ⁽⁷⁾	$T_J = +25^{\circ}\text{C}$	$V_I = 11.5\text{V to } 25\text{V}$	–	6.0	180	mV
			$V_I = 12\text{V to } 17\text{V}$	–	2.0	90.0	
Regload	Load Regulation ⁽⁷⁾	$T_J = +25^{\circ}\text{C}$	$I_O = 5\text{mA to } 1.5\text{A}$	–	12.0	180	mV
			$I_O = 250\text{mA to } 750\text{mA}$	–	4.0	90.0	
I_Q	Quiescent Current	$T_J = +25^{\circ}\text{C}$	–	5.0	8.0	mA	
ΔI_Q	Quiescent Current Change	$I_O = 5\text{mA to } 1\text{A}$	–	–	0.5	mA	
		$V_I = 11.5\text{V to } 26\text{V}$	–	–	1.3		
$\Delta V_O/\Delta T$	Output Voltage Drift ⁽⁸⁾	$I_O = 5\text{mA}$	–	-1.0	–	mV/ $^{\circ}\text{C}$	
V_N	Output Noise Voltage	$f = 10\text{Hz to } 100\text{kHz}$, $T_A = +25^{\circ}\text{C}$	–	58.0	–	$\mu\text{V}/V_O$	
RR	Ripple Rejection ⁽⁸⁾	$f = 120\text{Hz}$, $V_O = 13\text{V to } 23\text{V}$	56.0	71.0	–	dB	
V_{DROPP}	Dropout Voltage	$I_O = 1\text{A}$, $T_J = +25^{\circ}\text{C}$	–	2.0	–	V	
r_O	Output Resistance ⁽⁸⁾	$f = 1\text{kHz}$	–	17.0	–	m Ω	
I_{SC}	Short Circuit Current	$V_I = 35\text{V}$, $T_A = +25^{\circ}\text{C}$	–	250	–	mA	
I_{PK}	Peak Current ⁽⁸⁾	$T_J = +25^{\circ}\text{C}$	–	2.2	–	A	

Notes:

- Load and line regulation are specified at constant junction temperature. Changes in V_O due to heating effects must be taken into account separately. Pulse testing with low duty is used.
- These parameters, although guaranteed, are not 100% tested in production.

Electrical Characteristics (LM7810) (Continued)

Refer to the test circuits. $-40^{\circ}\text{C} < T_J < 125^{\circ}\text{C}$, $I_O = 500\text{mA}$, $V_I = 16\text{V}$, $C_I = 0.33\mu\text{F}$, $C_O = 0.1\mu\text{F}$, unless otherwise specified.

Symbol	Parameter	Conditions	Min.	Typ.	Max.	Unit	
V_O	Output Voltage	$T_J = +25^{\circ}\text{C}$	9.6	10.0	10.4	V	
		$5\text{mA} \leq I_O \leq 1\text{A}$, $P_O \leq 15\text{W}$, $V_I = 12.5\text{V to } 25\text{V}$	9.5	10.0	10.5		
Regline	Line Regulation ⁽⁹⁾	$T_J = +25^{\circ}\text{C}$	$V_I = 12.5\text{V to } 25\text{V}$	–	10.0	200	mV
			$V_I = 13\text{V to } 25\text{V}$	–	3.0	100	
Regload	Load Regulation ⁽⁹⁾	$T_J = +25^{\circ}\text{C}$	$I_O = 5\text{mA to } 1.5\text{A}$	–	12.0	200	mV
			$I_O = 250\text{mA to } 750\text{mA}$	–	4.0	400	
I_Q	Quiescent Current	$T_J = +25^{\circ}\text{C}$	–	5.1	8.0	mA	
ΔI_Q	Quiescent Current Change	$I_O = 5\text{mA to } 1\text{A}$	–	–	0.5	mA	
		$V_I = 12.5\text{V to } 29\text{V}$	–	–	1.0		
$\Delta V_O/\Delta T$	Output Voltage Drift ⁽¹⁰⁾	$I_O = 5\text{mA}$	–	-1.0	–	mV/ $^{\circ}\text{C}$	
V_N	Output Noise Voltage	$f = 10\text{Hz to } 100\text{kHz}$, $T_A = +25^{\circ}\text{C}$	–	58.0	–	$\mu\text{V}/V_O$	
RR	Ripple Rejection ⁽¹⁰⁾	$f = 120\text{Hz}$, $V_O = 13\text{V to } 23\text{V}$	56.0	71.0	–	dB	
V_{DROP}	Dropout Voltage	$I_O = 1\text{A}$, $T_J = +25^{\circ}\text{C}$	–	2.0	–	V	
r_O	Output Resistance ⁽¹⁰⁾	$f = 1\text{kHz}$	–	17.0	–	$\text{m}\Omega$	
I_{SC}	Short Circuit Current	$V_I = 35\text{V}$, $T_A = +25^{\circ}\text{C}$	–	250	–	mA	
I_{PK}	Peak Current ⁽¹⁰⁾	$T_J = +25^{\circ}\text{C}$	–	2.2	–	A	

Notes:

9. Load and line regulation are specified at constant junction temperature. Changes in V_O due to heating effects must be taken into account separately. Pulse testing with low duty is used.
10. These parameters, although guaranteed, are not 100% tested in production.

Electrical Characteristics (LM7812) (Continued)

Refer to the test circuits. $-40^{\circ}\text{C} < T_J < 125^{\circ}\text{C}$, $I_O = 500\text{mA}$, $V_I = 19\text{V}$, $C_I = 0.33\mu\text{F}$, $C_O = 0.1\mu\text{F}$, unless otherwise specified.

Symbol	Parameter	Conditions	Min.	Typ.	Max.	Unit	
V_O	Output Voltage	$T_J = +25^{\circ}\text{C}$	11.5	12.0	12.5	V	
		$5\text{mA} \leq I_O \leq 1\text{A}$, $P_O \leq 15\text{W}$, $V_I = 14.5\text{V to } 27\text{V}$	11.4	12.0	12.6		
Regline	Line Regulation ⁽¹¹⁾	$T_J = +25^{\circ}\text{C}$	$V_I = 14.5\text{V to } 30\text{V}$	–	10.0	240	mV
			$V_I = 16\text{V to } 22\text{V}$	–	3.0	120	
Regload	Load Regulation ⁽¹¹⁾	$T_J = +25^{\circ}\text{C}$	$I_O = 5\text{mA to } 1.5\text{A}$	–	11.0	240	mV
			$I_O = 250\text{mA to } 750\text{mA}$	–	5.0	120	
I_Q	Quiescent Current	$T_J = +25^{\circ}\text{C}$	–	5.1	8.0	mA	
ΔI_Q	Quiescent Current Change	$I_O = 5\text{mA to } 1\text{A}$	–	0.1	0.5	mA	
		$V_I = 14.5\text{V to } 30\text{V}$	–	0.5	1.0		
$\Delta V_O/\Delta T$	Output Voltage Drift ⁽¹²⁾	$I_O = 5\text{mA}$	–	-1.0	–	mV/ $^{\circ}\text{C}$	
V_N	Output Noise Voltage	$f = 10\text{Hz to } 100\text{kHz}$, $T_A = +25^{\circ}\text{C}$	–	76.0	–	$\mu\text{V}/V_O$	
RR	Ripple Rejection ⁽¹²⁾	$f = 120\text{Hz}$, $V_I = 15\text{V to } 25\text{V}$	55.0	71.0	–	dB	
V_{DROP}	Dropout Voltage	$I_O = 1\text{A}$, $T_J = +25^{\circ}\text{C}$	–	2.0	–	V	
r_O	Output Resistance ⁽¹²⁾	$f = 1\text{kHz}$	–	18.0	–	m Ω	
I_{SC}	Short Circuit Current	$V_I = 35\text{V}$, $T_A = +25^{\circ}\text{C}$	–	230	–	mA	
I_{PK}	Peak Current ⁽¹²⁾	$T_J = +25^{\circ}\text{C}$	–	2.2	–	A	

Notes:

- Load and line regulation are specified at constant junction temperature. Changes in V_O due to heating effects must be taken into account separately. Pulse testing with low duty is used.
- These parameters, although guaranteed, are not 100% tested in production.

Electrical Characteristics (LM7815) (Continued)

Refer to the test circuits. $-40^{\circ}\text{C} < T_J < 125^{\circ}\text{C}$, $I_O = 500\text{mA}$, $V_I = 23\text{V}$, $C_I = 0.33\mu\text{F}$, $C_O = 0.1\mu\text{F}$, unless otherwise specified.

Symbol	Parameter	Conditions	Min.	Typ.	Max.	Unit	
V_O	Output Voltage	$T_J = +25^{\circ}\text{C}$	14.4	15.0	15.6	V	
		$5\text{mA} \leq I_O \leq 1\text{A}$, $P_O \leq 15\text{W}$, $V_I = 17.5\text{V to } 30\text{V}$	14.25	15.0	15.75		
Regline	Line Regulation ⁽¹³⁾	$T_J = +25^{\circ}\text{C}$	$V_I = 17.5\text{V to } 30\text{V}$	–	11.0	300	mV
			$V_I = 20\text{V to } 26\text{V}$	–	3.0	150	
Regload	Load Regulation ⁽¹³⁾	$T_J = +25^{\circ}\text{C}$	$I_O = 5\text{mA to } 1.5\text{A}$	–	12.0	300	mV
			$I_O = 250\text{mA to } 750\text{mA}$	–	4.0	150	
I_Q	Quiescent Current	$T_J = +25^{\circ}\text{C}$	–	5.2	8.0	mA	
ΔI_Q	Quiescent Current Change	$I_O = 5\text{mA to } 1\text{A}$	–	–	0.5	mA	
		$V_I = 17.5\text{V to } 30\text{V}$	–	–	1.0		
$\Delta V_O/\Delta T$	Output Voltage Drift ⁽¹⁴⁾	$I_O = 5\text{mA}$	–	-1.0	–	mV/ $^{\circ}\text{C}$	
V_N	Output Noise Voltage	$f = 10\text{Hz to } 100\text{kHz}$, $T_A = +25^{\circ}\text{C}$	–	90.0	–	$\mu\text{V}/V_O$	
RR	Ripple Rejection ⁽¹⁴⁾	$f = 120\text{Hz}$, $V_I = 18.5\text{V to } 28.5\text{V}$	54.0	70.0	–	dB	
V_{DROP}	Dropout Voltage	$I_O = 1\text{A}$, $T_J = +25^{\circ}\text{C}$	–	2.0	–	V	
r_O	Output Resistance ⁽¹⁴⁾	$f = 1\text{kHz}$	–	19.0	–	m Ω	
I_{SC}	Short Circuit Current	$V_I = 35\text{V}$, $T_A = +25^{\circ}\text{C}$	–	250	–	mA	
I_{PK}	Peak Current ⁽¹⁴⁾	$T_J = +25^{\circ}\text{C}$	–	2.2	–	A	

Notes:

13. Load and line regulation are specified at constant junction temperature. Changes in V_O due to heating effects must be taken into account separately. Pulse testing with low duty is used.
14. These parameters, although guaranteed, are not 100% tested in production.

Electrical Characteristics (LM7818) (Continued)

Refer to the test circuits. $-40^{\circ}\text{C} < T_J < 125^{\circ}\text{C}$, $I_O = 500\text{mA}$, $V_I = 27\text{V}$, $C_I = 0.33\mu\text{F}$, $C_O = 0.1\mu\text{F}$, unless otherwise specified.

Symbol	Parameter	Conditions	Min.	Typ.	Max.	Unit	
V_O	Output Voltage	$T_J = +25^{\circ}\text{C}$	17.3	18.0	18.7	V	
		$5\text{mA} \leq I_O \leq 1\text{A}$, $P_O \leq 15\text{W}$, $V_I = 21\text{V to } 33\text{V}$	17.1	18.0	18.9		
Regline	Line Regulation ⁽¹⁵⁾	$T_J = +25^{\circ}\text{C}$	$V_I = 21\text{V to } 33\text{V}$	–	15.0	360	mV
			$V_I = 24\text{V to } 30\text{V}$	–	5.0	180	
Regload	Load Regulation ⁽¹⁵⁾	$T_J = +25^{\circ}\text{C}$	$I_O = 5\text{mA to } 1.5\text{A}$	–	15.0	360	mV
			$I_O = 250\text{mA to } 750\text{mA}$	–	5.0	180	
I_Q	Quiescent Current	$T_J = +25^{\circ}\text{C}$	–	5.2	8.0	mA	
ΔI_Q	Quiescent Current Change	$I_O = 5\text{mA to } 1\text{A}$	–	–	0.5	mA	
		$V_I = 21\text{V to } 33\text{V}$	–	–	1.0		
$\Delta V_O/\Delta T$	Output Voltage Drift ⁽¹⁶⁾	$I_O = 5\text{mA}$	–	-1.0	–	mV/ $^{\circ}\text{C}$	
V_N	Output Noise Voltage	$f = 10\text{Hz to } 100\text{kHz}$, $T_A = +25^{\circ}\text{C}$	–	110	–	$\mu\text{V}/V_O$	
RR	Ripple Rejection ⁽¹⁶⁾	$f = 120\text{Hz}$, $V_I = 22\text{V to } 32\text{V}$	53.0	69.0	–	dB	
V_{DROPP}	Dropout Voltage	$I_O = 1\text{A}$, $T_J = +25^{\circ}\text{C}$	–	2.0	–	V	
r_O	Output Resistance ⁽¹⁶⁾	$f = 1\text{kHz}$	–	22.0	–	m Ω	
I_{SC}	Short Circuit Current	$V_I = 35\text{V}$, $T_A = +25^{\circ}\text{C}$	–	250	–	mA	
I_{PK}	Peak Current ⁽¹⁶⁾	$T_J = +25^{\circ}\text{C}$	–	2.2	–	A	

Notes:

15. Load and line regulation are specified at constant junction temperature. Changes in V_O due to heating effects must be taken into account separately. Pulse testing with low duty is used.
16. These parameters, although guaranteed, are not 100% tested in production.

Electrical Characteristics (LM7824) (Continued)

Refer to the test circuits. $-40^{\circ}\text{C} < T_J < 125^{\circ}\text{C}$, $I_O = 500\text{mA}$, $V_I = 33\text{V}$, $C_I = 0.33\mu\text{F}$, $C_O = 0.1\mu\text{F}$, unless otherwise specified.

Symbol	Parameter	Conditions	Min.	Typ.	Max.	Unit	
V_O	Output Voltage	$T_J = +25^{\circ}\text{C}$	23.0	24.0	25.0	V	
		$5\text{mA} \leq I_O \leq 1\text{A}$, $P_O \leq 15\text{W}$, $V_I = 27\text{V to } 38\text{V}$	22.8	24.0	25.25		
Regline	Line Regulation ⁽¹⁷⁾	$T_J = +25^{\circ}\text{C}$	$V_I = 27\text{V to } 38\text{V}$	–	17.0	480	mV
			$V_I = 30\text{V to } 36\text{V}$	–	6.0	240	
Regload	Load Regulation ⁽¹⁷⁾	$T_J = +25^{\circ}\text{C}$	$I_O = 5\text{mA to } 1.5\text{A}$	–	15.0	480	mV
			$I_O = 250\text{mA to } 750\text{mA}$	–	5.0	240	
I_Q	Quiescent Current	$T_J = +25^{\circ}\text{C}$	–	5.2	8.0	mA	
ΔI_Q	Quiescent Current Change	$I_O = 5\text{mA to } 1\text{A}$	–	0.1	0.5	mA	
		$V_I = 27\text{V to } 38\text{V}$	–	0.5	1.0		
$\Delta V_O/\Delta T$	Output Voltage Drift ⁽¹⁸⁾	$I_O = 5\text{mA}$	–	-1.5	–	mV/ $^{\circ}\text{C}$	
V_N	Output Noise Voltage	$f = 10\text{Hz to } 100\text{kHz}$, $T_A = +25^{\circ}\text{C}$	–	60.0	–	$\mu\text{V}/V_O$	
RR	Ripple Rejection ⁽¹⁸⁾	$f = 120\text{Hz}$, $V_I = 28\text{V to } 38\text{V}$	50.0	67.0	–	dB	
V_{DROP}	Dropout Voltage	$I_O = 1\text{A}$, $T_J = +25^{\circ}\text{C}$	–	2.0	–	V	
rO	Output Resistance ⁽¹⁸⁾	$f = 1\text{kHz}$	–	28.0	–	m Ω	
I_{SC}	Short Circuit Current	$V_I = 35\text{V}$, $T_A = +25^{\circ}\text{C}$	–	230	–	mA	
I_{PK}	Peak Current ⁽¹⁸⁾	$T_J = +25^{\circ}\text{C}$	–	2.2	–	A	

Notes:

17. Load and line regulation are specified at constant junction temperature. Changes in V_O due to heating effects must be taken into account separately. Pulse testing with low duty is used.
18. These parameters, although guaranteed, are not 100% tested in production.

Electrical Characteristics (LM7805A) (Continued)

Refer to the test circuits. $0^{\circ}\text{C} < T_J < 125^{\circ}\text{C}$, $I_O = 1\text{A}$, $V_I = 10\text{V}$, $C_I = 0.33\mu\text{F}$, $C_O = 0.1\mu\text{F}$, unless otherwise specified.

Symbol	Parameter	Conditions	Min.	Typ.	Max.	Unit	
V_O	Output Voltage	$T_J = +25^{\circ}\text{C}$	4.9	5.0	5.1	V	
		$I_O = 5\text{mA to } 1\text{A}$, $P_O \leq 15\text{W}$, $V_I = 7.5\text{V to } 20\text{V}$	4.8	5.0	5.2		
Regline	Line Regulation ⁽¹⁹⁾	$V_I = 7.5\text{V to } 25\text{V}$, $I_O = 500\text{mA}$	–	5.0	50.0	mV	
		$V_I = 8\text{V to } 12\text{V}$	–	3.0	50.0		
		$T_J = +25^{\circ}\text{C}$	$V_I = 7.3\text{V to } 20\text{V}$	–	5.0		50.0
			$V_I = 8\text{V to } 12\text{V}$	–	1.5		25.0
Regload	Load Regulation ⁽¹⁹⁾	$T_J = +25^{\circ}\text{C}$, $I_O = 5\text{mA to } 1.5\text{A}$	–	9.0	100	mV	
		$I_O = 5\text{mA to } 1\text{A}$	–	9.0	100		
		$I_O = 250\text{mA to } 750\text{mA}$	–	4.0	50.0		
I_Q	Quiescent Current	$T_J = +25^{\circ}\text{C}$	–	5.0	6.0	mA	
ΔI_Q	Quiescent Current Change	$I_O = 5\text{mA to } 1\text{A}$	–	–	0.5	mA	
		$V_I = 8\text{V to } 25\text{V}$, $I_O = 500\text{mA}$	–	–	0.8		
		$V_I = 7.5\text{V to } 20\text{V}$, $T_J = +25^{\circ}\text{C}$	–	–	0.8		
$\Delta V_O/\Delta T$	Output Voltage Drift ⁽²⁰⁾	$I_O = 5\text{mA}$	–	-0.8	–	mV/ $^{\circ}\text{C}$	
V_N	Output Noise Voltage	$f = 10\text{Hz to } 100\text{kHz}$, $T_A = +25^{\circ}\text{C}$	–	10.0	–	$\mu\text{V}/V_O$	
RR	Ripple Rejection ⁽²⁰⁾	$f = 120\text{Hz}$, $I_O = 500\text{mA}$, $V_I = 8\text{V to } 18\text{V}$	–	68.0	–	dB	
V_{DROP}	Dropout Voltage	$I_O = 1\text{A}$, $T_J = +25^{\circ}\text{C}$	–	2.0	–	V	
r_O	Output Resistance ⁽²⁰⁾	$f = 1\text{kHz}$	–	17.0	–	m Ω	
I_{SC}	Short Circuit Current	$V_I = 35\text{V}$, $T_A = +25^{\circ}\text{C}$	–	250	–	mA	
I_{PK}	Peak Current ⁽²⁰⁾	$T_J = +25^{\circ}\text{C}$	–	2.2	–	A	

Notes:

19. Load and line regulation are specified at constant junction temperature. Changes in V_O due to heating effects must be taken into account separately. Pulse testing with low duty is used.

20. These parameters, although guaranteed, are not 100% tested in production.

Electrical Characteristics (LM7806A) (Continued)

Refer to the test circuits. $0^{\circ}\text{C} < T_J < 125^{\circ}\text{C}$, $I_O = 1\text{A}$, $V_I = 11\text{V}$, $C_I = 0.33\mu\text{F}$, $C_O = 0.1\mu\text{F}$, unless otherwise specified.

Symbol	Parameter	Conditions	Min.	Typ.	Max.	Unit
V_O	Output Voltage	$T_J = +25^{\circ}\text{C}$	5.58	6.0	6.12	V
		$I_O = 5\text{mA to } 1\text{A}$, $P_O \leq 15\text{W}$, $V_I = 8.6\text{V to } 21\text{V}$	5.76	6.0	6.24	
Regline	Line Regulation ⁽²¹⁾	$V_I = 8.6\text{V to } 25\text{V}$, $I_O = 500\text{mA}$	–	5.0	60.0	mV
		$V_I = 9\text{V to } 13\text{V}$	–	3.0	60.0	
		$T_J = +25^{\circ}\text{C}$, $V_I = 8.3\text{V to } 21\text{V}$	–	5.0	60.0	
		$V_I = 9\text{V to } 13\text{V}$	–	1.5	30.0	
Regload	Load Regulation ⁽²¹⁾	$T_J = +25^{\circ}\text{C}$, $I_O = 5\text{mA to } 1.5\text{A}$	–	9.0	100	mV
		$I_O = 5\text{mA to } 1\text{A}$	–	9.0	100	
		$I_O = 250\text{mA to } 750\text{mA}$	–	5.0	50.0	
I_Q	Quiescent Current	$T_J = +25^{\circ}\text{C}$	–	4.3	6.0	mA
ΔI_Q	Quiescent Current Change	$I_O = 5\text{mA to } 1\text{A}$	–	–	0.5	mA
		$V_I = 19\text{V to } 25\text{V}$, $I_O = 500\text{mA}$	–	–	0.8	
		$V_I = 8.5\text{V to } 21\text{V}$, $T_J = +25^{\circ}\text{C}$	–	–	0.8	
$\Delta V_O/\Delta T$	Output Voltage Drift ⁽²²⁾	$I_O = 5\text{mA}$	–	-0.8	–	mV/ $^{\circ}\text{C}$
V_N	Output Noise Voltage	$f = 10\text{Hz to } 100\text{kHz}$, $T_A = +25^{\circ}\text{C}$	–	10.0	–	$\mu\text{V}/V_O$
RR	Ripple Rejection ⁽²²⁾	$f = 120\text{Hz}$, $I_O = 500\text{mA}$, $V_I = 9\text{V to } 19\text{V}$	–	65.0	–	dB
V_{DROP}	Dropout Voltage	$I_O = 1\text{A}$, $T_J = +25^{\circ}\text{C}$	–	2.0	–	V
r_O	Output Resistance ⁽²²⁾	$f = 1\text{kHz}$	–	17.0	–	$\text{m}\Omega$
I_{SC}	Short Circuit Current	$V_I = 35\text{V}$, $T_A = +25^{\circ}\text{C}$	–	250	–	mA
I_{PK}	Peak Current ⁽²²⁾	$T_J = +25^{\circ}\text{C}$	–	2.2	–	A

Notes:

21. Load and line regulation are specified at constant junction temperature. Changes in V_O due to heating effects must be taken into account separately. Pulse testing with low duty is used.

22. These parameters, although guaranteed, are not 100% tested in production.

Electrical Characteristics (LM7808A) (Continued)

Refer to the test circuits. $0^{\circ}\text{C} < T_J < 125^{\circ}\text{C}$, $I_O = 1\text{A}$, $V_I = 14\text{V}$, $C_I = 0.33\mu\text{F}$, $C_O = 0.1\mu\text{F}$, unless otherwise specified.

Symbol	Parameter	Conditions	Min.	Typ.	Max.	Unit	
V_O	Output Voltage	$T_J = +25^{\circ}\text{C}$	7.84	8.0	8.16	V	
		$I_O = 5\text{mA}$ to 1A , $P_O \leq 15\text{W}$, $V_I = 10.6\text{V}$ to 23V	7.7	8.0	8.3		
Regline	Line Regulation ⁽²³⁾	$V_I = 10.6\text{V}$ to 25V , $I_O = 500\text{mA}$	–	6.0	80.0	mV	
		$V_I = 11\text{V}$ to 17V	–	3.0	80.0		
		$T_J = +25^{\circ}\text{C}$	$V_I = 10.4\text{V}$ to 23V	–	6.0		80.0
		$V_I = 11\text{V}$ to 17V	–	2.0	40.0		
Regload	Load Regulation ⁽²³⁾	$T_J = +25^{\circ}\text{C}$, $I_O = 5\text{mA}$ to 1.5A	–	12.0	100	mV	
		$I_O = 5\text{mA}$ to 1A	–	12.0	100		
		$I_O = 250\text{mA}$ to 750mA	–	5.0	50.0		
I_Q	Quiescent Current	$T_J = +25^{\circ}\text{C}$	–	5.0	6.0	mA	
ΔI_Q	Quiescent Current Change	$I_O = 5\text{mA}$ to 1A	–	–	0.5	mA	
		$V_I = 11\text{V}$ to 25V , $I_O = 500\text{mA}$	–	–	0.8		
		$V_I = 10.6\text{V}$ to 23V , $T_J = +25^{\circ}\text{C}$	–	–	0.8		
$\Delta V_O/\Delta T$	Output Voltage Drift ⁽²⁴⁾	$I_O = 5\text{mA}$	–	-0.8	–	mV/ $^{\circ}\text{C}$	
V_N	Output Noise Voltage	$f = 10\text{Hz}$ to 100kHz , $T_A = +25^{\circ}\text{C}$	–	10.0	–	$\mu\text{V}/V_O$	
RR	Ripple Rejection ⁽²⁴⁾	$f = 120\text{Hz}$, $I_O = 500\text{mA}$, $V_I = 11.5\text{V}$ to 21.5V	–	62.0	–	dB	
V_{DROPP}	Dropout Voltage	$I_O = 1\text{A}$, $T_J = +25^{\circ}\text{C}$	–	2.0	–	V	
r_O	Output Resistance ⁽²⁴⁾	$f = 1\text{kHz}$	–	18.0	–	m Ω	
I_{SC}	Short Circuit Current	$V_I = 35\text{V}$, $T_A = +25^{\circ}\text{C}$	–	250	–	mA	
I_{PK}	Peak Current ⁽²⁴⁾	$T_J = +25^{\circ}\text{C}$	–	2.2	–	A	

Notes:

23. Load and line regulation are specified at constant junction temperature. Changes in V_O due to heating effects must be taken into account separately. Pulse testing with low duty is used.

24. These parameters, although guaranteed, are not 100% tested in production.

Electrical Characteristics (LM7809A) (Continued)

Refer to the test circuits. $0^{\circ}\text{C} < T_J < 125^{\circ}\text{C}$, $I_O = 1\text{A}$, $V_I = 15\text{V}$, $C_I = 0.33\mu\text{F}$, $C_O = 0.1\mu\text{F}$, unless otherwise specified.

Symbol	Parameter	Conditions	Min.	Typ.	Max.	Units	
V_O	Output Voltage	$T_J = +25^{\circ}\text{C}$	8.82	9.0	9.16	V	
		$I_O = 5\text{mA to } 1\text{A}$, $P_O \leq 15\text{W}$, $V_I = 11.2\text{V to } 24\text{V}$	8.65	9.0	9.35		
Regline	Line Regulation ⁽²⁵⁾	$V_I = 11.7\text{V to } 25\text{V}$, $I_O = 500\text{mA}$	–	6.0	90.0	mV	
		$V_I = 12.5\text{V to } 19\text{V}$	–	4.0	45.0		
		$T_J = +25^{\circ}\text{C}$	$V_I = 11.5\text{V to } 24\text{V}$	–	6.0		90.0
		$V_I = 12.5\text{V to } 19\text{V}$	–	2.0	45.0		
Regload	Load Regulation ⁽²⁵⁾	$T_J = +25^{\circ}\text{C}$, $I_O = 5\text{mA to } 1.5\text{A}$	–	12.0	100	mV	
		$I_O = 5\text{mA to } 1\text{A}$	–	12.0	100		
		$I_O = 250\text{mA to } 750\text{mA}$	–	5.0	50.0		
I_Q	Quiescent Current	$T_J = +25^{\circ}\text{C}$	–	5.0	6.0	mA	
ΔI_Q	Quiescent Current Change	$I_O = 5\text{mA to } 1\text{A}$	–	–	0.5	mA	
		$V_I = 12\text{V to } 25\text{V}$, $I_O = 500\text{mA}$	–	–	0.8		
		$V_I = 11.7\text{V to } 25\text{V}$, $T_J = +25^{\circ}\text{C}$	–	–	0.8		
$\Delta V_O/\Delta T$	Output Voltage Drift ⁽²⁶⁾	$I_O = 5\text{mA}$	–	-1.0	–	mV/ $^{\circ}\text{C}$	
V_N	Output Noise Voltage	$f = 10\text{Hz to } 100\text{kHz}$, $T_A = +25^{\circ}\text{C}$	–	10.0	–	$\mu\text{V}/V_O$	
RR	Ripple Rejection ⁽²⁶⁾	$f = 120\text{Hz}$, $I_O = 500\text{mA}$, $V_I = 12\text{V to } 22\text{V}$	–	62.0	–	dB	
V_{DROP}	Dropout Voltage	$I_O = 1\text{A}$, $T_J = +25^{\circ}\text{C}$	–	2.0	–	V	
r_O	Output Resistance ⁽²⁶⁾	$f = 1\text{kHz}$	–	17.0	–	$\text{m}\Omega$	
I_{SC}	Short Circuit Current	$V_I = 35\text{V}$, $T_A = +25^{\circ}\text{C}$	–	250	–	mA	
I_{PK}	Peak Current ⁽²⁶⁾	$T_J = +25^{\circ}\text{C}$	–	2.2	–	A	

Notes:

25. Load and line regulation are specified at constant junction temperature. Changes in V_O due to heating effects must be taken into account separately. Pulse testing with low duty is used.

26. These parameters, although guaranteed, are not 100% tested in production.

Electrical Characteristics (LM7810A) (Continued)

Refer to the test circuits. $0^{\circ}\text{C} < T_J < 125^{\circ}\text{C}$, $I_O = 1\text{A}$, $V_I = 16\text{V}$, $C_I = 0.33\mu\text{F}$, $C_O = 0.1\mu\text{F}$, unless otherwise specified.

Symbol	Parameter	Conditions	Min.	Typ.	Max.	Units	
V_O	Output Voltage	$T_J = +25^{\circ}\text{C}$	9.8	10.0	10.2	V	
		$I_O = 5\text{mA to } 1\text{A}$, $P_O \leq 15\text{W}$, $V_I = 12.8\text{V to } 25\text{V}$	9.6	10.0	10.4		
Regline	Line Regulation ⁽²⁷⁾	$V_I = 12.8\text{V to } 26\text{V}$, $I_O = 500\text{mA}$	–	8.0	100	mV	
		$V_I = 13\text{V to } 20\text{V}$	–	4.0	50.0		
		$T_J = +25^{\circ}\text{C}$	$V_I = 12.5\text{V to } 25\text{V}$	–	8.0		100
			$V_I = 13\text{V to } 20\text{V}$	–	3.0		50.0
Regload	Load Regulation ⁽²⁷⁾	$T_J = +25^{\circ}\text{C}$, $I_O = 5\text{mA to } 1.5\text{A}$	–	12.0	100	mV	
		$I_O = 5\text{mA to } 1\text{A}$	–	12.0	100		
		$I_O = 250\text{mA to } 750\text{mA}$	–	5.0	50.0		
I_Q	Quiescent Current	$T_J = +25^{\circ}\text{C}$	–	5.0	6.0	mA	
ΔI_Q	Quiescent Current Change	$I_O = 5\text{mA to } 1\text{A}$	–	–	0.5	mA	
		$V_I = 12.8\text{V to } 25\text{V}$, $I_O = 500\text{mA}$	–	–	0.8		
		$V_I = 13\text{V to } 26\text{V}$, $T_J = +25^{\circ}\text{C}$	–	–	0.5		
$\Delta V_O/\Delta T$	Output Voltage Drift ⁽²⁸⁾	$I_O = 5\text{mA}$	–	-1.0	–	mV/ $^{\circ}\text{C}$	
V_N	Output Noise Voltage	$f = 10\text{Hz to } 100\text{kHz}$, $T_A = +25^{\circ}\text{C}$	–	10.0	–	$\mu\text{V}/V_O$	
RR	Ripple Rejection ⁽²⁸⁾	$f = 120\text{Hz}$, $I_O = 500\text{mA}$, $V_I = 14\text{V to } 24\text{V}$	–	62.0	–	dB	
V_{DROP}	Dropout Voltage	$I_O = 1\text{A}$, $T_J = +25^{\circ}\text{C}$	–	2.0	–	V	
r_O	Output Resistance ⁽²⁸⁾	$f = 1\text{kHz}$	–	17.0	–	m Ω	
I_{SC}	Short Circuit Current	$V_I = 35\text{V}$, $T_A = +25^{\circ}\text{C}$	–	250	–	mA	
I_{PK}	Peak Current ⁽²⁸⁾	$T_J = +25^{\circ}\text{C}$	–	2.2	–	A	

Notes:

27. Load and line regulation are specified at constant junction temperature. Changes in V_O due to heating effects must be taken into account separately. Pulse testing with low duty is used.

28. These parameters, although guaranteed, are not 100% tested in production.

Electrical Characteristics (LM7812A) (Continued)

Refer to the test circuits. $0^{\circ}\text{C} < T_J < 125^{\circ}\text{C}$, $I_O = 1\text{A}$, $V_I = 19\text{V}$, $C_I = 0.33\mu\text{F}$, $C_O = 0.1\mu\text{F}$, unless otherwise specified.

Symbol	Parameter	Conditions	Min.	Typ.	Max.	Units	
V_O	Output Voltage	$T_J = +25^{\circ}\text{C}$	11.75	12.0	12.25	V	
		$I_O = 5\text{mA to } 1\text{A}$, $P_O \leq 15\text{W}$, $V_I = 14.8\text{V to } 27\text{V}$	11.5	12.0	12.5		
Regline	Line Regulation ⁽²⁹⁾	$V_I = 14.8\text{V to } 30\text{V}$, $I_O = 500\text{mA}$	–	10.0	120	mV	
		$V_I = 16\text{V to } 22\text{V}$	–	4.0	120		
		$T_J = +25^{\circ}\text{C}$	$V_I = 14.5\text{V to } 27\text{V}$ $V_I = 16\text{V to } 22\text{V}$	–	10.0		120
		–		3.0	60.0		
Regload	Load Regulation ⁽²⁹⁾	$T_J = +25^{\circ}\text{C}$, $I_O = 5\text{mA to } 1.5\text{A}$	–	12.0	100	mV	
		$I_O = 5\text{mA to } 1\text{A}$	–	12.0	100		
		$I_O = 250\text{mA to } 750\text{mA}$	–	5.0	50.0		
I_Q	Quiescent Current	$T_J = +25^{\circ}\text{C}$	–	5.1	6.0	mA	
ΔI_Q	Quiescent Current Change	$I_O = 5\text{mA to } 1\text{A}$	–	–	0.5	mA	
		$V_I = 14\text{V to } 27\text{V}$, $I_O = 500\text{mA}$	–	–	0.8		
		$V_I = 15\text{V to } 30\text{V}$, $T_J = +25^{\circ}\text{C}$	–	–	0.8		
$\Delta V_O/\Delta T$	Output Voltage Drift ⁽³⁰⁾	$I_O = 5\text{mA}$	–	-1.0	–	mV/ $^{\circ}\text{C}$	
V_N	Output Noise Voltage	$f = 10\text{Hz to } 100\text{kHz}$, $T_A = +25^{\circ}\text{C}$	–	10.0	–	$\mu\text{V}/V_O$	
RR	Ripple Rejection ⁽³⁰⁾	$f = 120\text{Hz}$, $I_O = 500\text{mA}$, $V_I = 14\text{V to } 24\text{V}$	–	60.0	–	dB	
V_{DROPP}	Dropout Voltage	$I_O = 1\text{A}$, $T_J = +25^{\circ}\text{C}$	–	2.0	–	V	
r_O	Output Resistance ⁽³⁰⁾	$f = 1\text{kHz}$	–	18.0	–	$\text{m}\Omega$	
I_{SC}	Short Circuit Current	$V_I = 35\text{V}$, $T_A = +25^{\circ}\text{C}$	–	250	–	mA	
I_{PK}	Peak Current ⁽³⁰⁾	$T_J = +25^{\circ}\text{C}$	–	2.2	–	A	

Note:

29. Load and line regulation are specified at constant junction temperature. Changes in V_O due to heating effects must be taken into account separately. Pulse testing with low duty is used.

30. These parameters, although guaranteed, are not 100% tested in production.

Electrical Characteristics (LM7815A) (Continued)

Refer to the test circuits. $0^{\circ}\text{C} < T_J < 125^{\circ}\text{C}$, $I_O = 1\text{A}$, $V_I = 23\text{V}$, $C_I = 0.33\mu\text{F}$, $C_O = 0.1\mu\text{F}$, unless otherwise specified.

Symbol	Parameter	Conditions	Min.	Typ.	Max.	Units	
V_O	Output Voltage	$T_J = +25^{\circ}\text{C}$	14.75	15.0	15.3	V	
		$I_O = 5\text{mA to } 1\text{A}$, $P_O \leq 15\text{W}$, $V_I = 17.7\text{V to } 30\text{V}$	14.4	15.0	15.6		
Regline	Line Regulation ⁽³¹⁾	$V_I = 17.4\text{V to } 30\text{V}$, $I_O = 500\text{mA}$	–	10.0	150	mV	
		$V_I = 20\text{V to } 26\text{V}$	–	5.0	150		
		$T_J = +25^{\circ}\text{C}$	$V_I = 17.5\text{V to } 30\text{V}$	–	11.0		150
			$V_I = 20\text{V to } 26\text{V}$	–	3.0		75.0
Regload	Load Regulation ⁽³¹⁾	$T_J = +25^{\circ}\text{C}$, $I_O = 5\text{mA to } 1.5\text{A}$	–	12.0	100	mV	
		$I_O = 5\text{mA to } 1\text{A}$	–	12.0	100		
		$I_O = 250\text{mA to } 750\text{mA}$	–	5.0	50.0		
I_Q	Quiescent Current	$T_J = +25^{\circ}\text{C}$	–	5.2	6.0	mA	
ΔI_Q	Quiescent Current Change	$I_O = 5\text{mA to } 1\text{A}$	–	–	0.5	mA	
		$V_I = 17.5\text{V to } 30\text{V}$, $I_O = 500\text{mA}$	–	–	0.8		
		$V_I = 17.5\text{V to } 30\text{V}$, $T_J = +25^{\circ}\text{C}$	–	–	0.8		
$\Delta V_O/\Delta T$	Output Voltage Drift ⁽³²⁾	$I_O = 5\text{mA}$	–	-1.0	–	mV/ $^{\circ}\text{C}$	
V_N	Output Noise Voltage	$f = 10\text{Hz to } 100\text{kHz}$, $T_A = +25^{\circ}\text{C}$	–	10.0	–	$\mu\text{V}/V_O$	
RR	Ripple Rejection ⁽³²⁾	$f = 120\text{Hz}$, $I_O = 500\text{mA}$, $V_I = 18.5\text{V to } 28.5\text{V}$	–	58.0	–	dB	
V_{DROPP}	Dropout Voltage	$I_O = 1\text{A}$, $T_J = +25^{\circ}\text{C}$	–	2.0	–	V	
r_O	Output Resistance ⁽³²⁾	$f = 1\text{kHz}$	–	19.0	–	m Ω	
I_{SC}	Short Circuit Current	$V_I = 35\text{V}$, $T_A = +25^{\circ}\text{C}$	–	250	–	mA	
I_{PK}	Peak Current ⁽³²⁾	$T_J = +25^{\circ}\text{C}$	–	2.2	–	A	

Notes:

31. Load and line regulation are specified at constant junction temperature. Changes in V_O due to heating effects must be taken into account separately. Pulse testing with low duty is used.

32. These parameters, although guaranteed, are not 100% tested in production.

Electrical Characteristics (LM7818A) (Continued)

Refer to the test circuits. $0^{\circ}\text{C} < T_J < 125^{\circ}\text{C}$, $I_O = 1\text{A}$, $V_I = 27\text{V}$, $C_I = 0.33\mu\text{F}$, $C_O = 0.1\mu\text{F}$, unless otherwise specified.

Symbol	Parameter	Conditions	Min.	Typ.	Max.	Units	
V_O	Output Voltage	$T_J = +25^{\circ}\text{C}$	17.64	18.0	18.36	V	
		$I_O = 5\text{mA to } 1\text{A}$, $P_O \leq 15\text{W}$, $V_I = 21\text{V to } 33\text{V}$	17.3	18.0	18.7		
Regline	Line Regulation ⁽³³⁾	$V_I = 21\text{V to } 33\text{V}$, $I_O = 500\text{mA}$	–	15.0	180	mV	
		$V_I = 21\text{V to } 33\text{V}$	–	5.0	180		
		$T_J = +25^{\circ}\text{C}$	$V_I = 20.6\text{V to } 33\text{V}$	–	15.0		180
			$V_I = 24\text{V to } 30\text{V}$	–	5.0		90.0
Regload	Load Regulation ⁽³³⁾	$T_J = +25^{\circ}\text{C}$, $I_O = 5\text{mA to } 1.5\text{A}$	–	15.0	100	mV	
		$I_O = 5\text{mA to } 1\text{A}$	–	15.0	100		
		$I_O = 250\text{mA to } 750\text{mA}$	–	7.0	50.0		
I_Q	Quiescent Current	$T_J = +25^{\circ}\text{C}$	–	5.2	6.0	mA	
ΔI_Q	Quiescent Current Change	$I_O = 5\text{mA to } 1\text{A}$	–	–	0.5	mA	
		$V_I = 12\text{V to } 33\text{V}$, $I_O = 500\text{mA}$	–	–	0.8		
		$V_I = 12\text{V to } 33\text{V}$, $T_J = +25^{\circ}\text{C}$	–	–	0.8		
$\Delta V_O/\Delta T$	Output Voltage Drift ⁽³⁴⁾	$I_O = 5\text{mA}$	–	-1.0	–	mV/ $^{\circ}\text{C}$	
V_N	Output Noise Voltage	$f = 10\text{Hz to } 100\text{kHz}$, $T_A = +25^{\circ}\text{C}$	–	10.0	–	$\mu\text{V}/V_O$	
RR	Ripple Rejection ⁽³⁴⁾	$f = 120\text{Hz}$, $I_O = 500\text{mA}$, $V_I = 22\text{V to } 32\text{V}$	–	57.0	–	dB	
V_{DROP}	Dropout Voltage	$I_O = 1\text{A}$, $T_J = +25^{\circ}\text{C}$	–	2.0	–	V	
r_O	Output Resistance ⁽³⁴⁾	$f = 1\text{kHz}$	–	19.0	–	$\text{m}\Omega$	
I_{SC}	Short Circuit Current	$V_I = 35\text{V}$, $T_A = +25^{\circ}\text{C}$	–	250	–	mA	
I_{PK}	Peak Current ⁽³⁴⁾	$T_J = +25^{\circ}\text{C}$	–	2.2	–	A	

Notes:

33. Load and line regulation are specified at constant junction temperature. Changes in V_O due to heating effects must be taken into account separately. Pulse testing with low duty is used.

34. These parameters, although guaranteed, are not 100% tested in production.

Electrical Characteristics (LM7824A) (Continued)

Refer to the test circuits. $0^{\circ}\text{C} < T_J < 125^{\circ}\text{C}$, $I_O = 1\text{A}$, $V_I = 33\text{V}$, $C_I = 0.33\mu\text{F}$, $C_O = 0.1\mu\text{F}$, unless otherwise specified.

Symbol	Parameter	Conditions	Min.	Typ.	Max.	Units	
V_O	Output Voltage	$T_J = +25^{\circ}\text{C}$	23.5	24.0	24.5	V	
		$I_O = 5\text{mA to } 1\text{A}$, $P_O \leq 15\text{W}$, $V_I = 27.3\text{V to } 38\text{V}$	23.0	24.0	25.0		
Regline	Line Regulation ⁽³⁵⁾	$V_I = 27\text{V to } 38\text{V}$, $I_O = 500\text{mA}$	–	18.0	240	mV	
		$V_I = 21\text{V to } 33\text{V}$	–	6.0	240		
		$T_J = +25^{\circ}\text{C}$	$V_I = 26.7\text{V to } 38\text{V}$	–	18.0		240
			$V_I = 30\text{V to } 36\text{V}$	–	6.0		120
Regload	Load Regulation ⁽³⁵⁾	$T_J = +25^{\circ}\text{C}$, $I_O = 5\text{mA to } 1.5\text{A}$	–	15.0	100	mV	
		$I_O = 5\text{mA to } 1\text{A}$	–	15.0	100		
		$I_O = 250\text{mA to } 750\text{mA}$	–	7.0	50.0		
I_Q	Quiescent Current	$T_J = +25^{\circ}\text{C}$	–	5.2	6.0	mA	
ΔI_Q	Quiescent Current Change	$I_O = 5\text{mA to } 1\text{A}$	–	–	0.5	mA	
		$V_I = 27.3\text{V to } 38\text{V}$, $I_O = 500\text{mA}$	–	–	0.8		
		$V_I = 27.3\text{V to } 38\text{V}$, $T_J = +25^{\circ}\text{C}$	–	–	0.8		
$\Delta V_O/\Delta T$	Output Voltage Drift ⁽³⁶⁾	$I_O = 5\text{mA}$	–	-1.5	–	mV/ $^{\circ}\text{C}$	
V_N	Output Noise Voltage	$f = 10\text{Hz to } 100\text{kHz}$, $T_A = +25^{\circ}\text{C}$	–	10.0	–	$\mu\text{V}/V_O$	
RR	Ripple Rejection ⁽³⁶⁾	$f = 120\text{Hz}$, $I_O = 500\text{mA}$, $V_I = 28\text{V to } 38\text{V}$	–	54.0	–	dB	
V_{DROP}	Dropout Voltage	$I_O = 1\text{A}$, $T_J = +25^{\circ}\text{C}$	–	2.0	–	V	
r_O	Output Resistance ⁽³⁶⁾	$f = 1\text{kHz}$	–	20.0	–	m Ω	
I_{SC}	Short Circuit Current	$V_I = 35\text{V}$, $T_A = +25^{\circ}\text{C}$	–	250	–	mA	
I_{PK}	Peak Current ⁽³⁶⁾	$T_J = +25^{\circ}\text{C}$	–	2.2	–	A	

Notes:

35. Load and line regulation are specified at constant junction temperature. Changes in V_O due to heating effects must be taken into account separately. Pulse testing with low duty is used.

36. These parameters, although guaranteed, are not 100% tested in production.

Typical Performance Characteristics

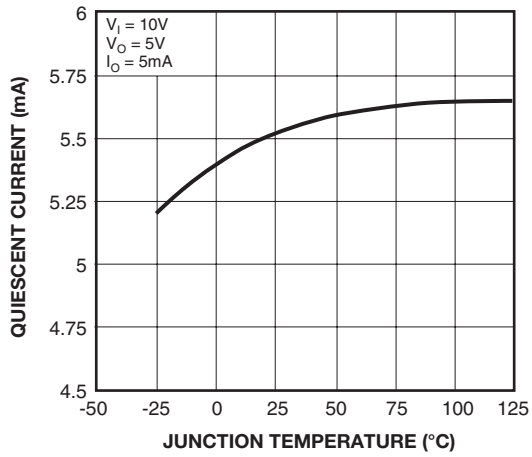

Figure 3. Quiescent Current

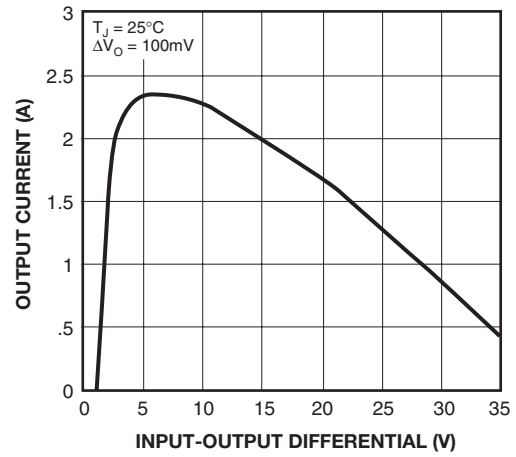

Figure 4. Peak Output Current

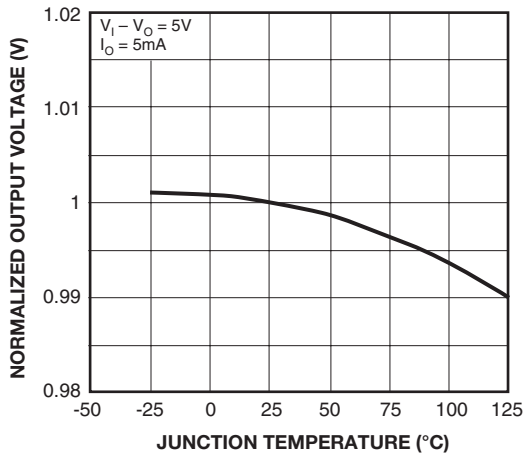

Figure 5. Output Voltage

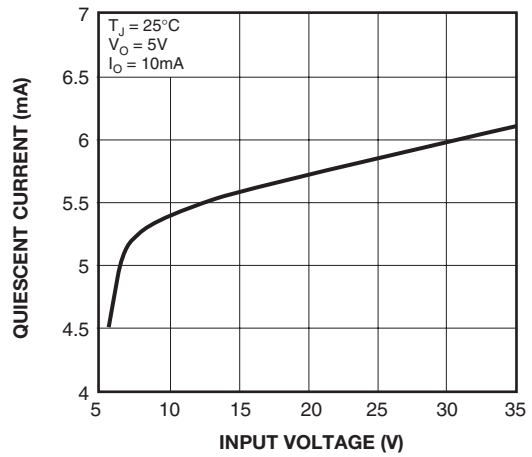

Figure 6. Quiescent Current

Typical Applications

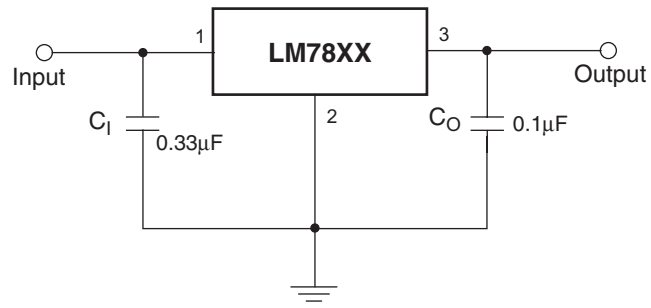

Figure 7. DC Parameters

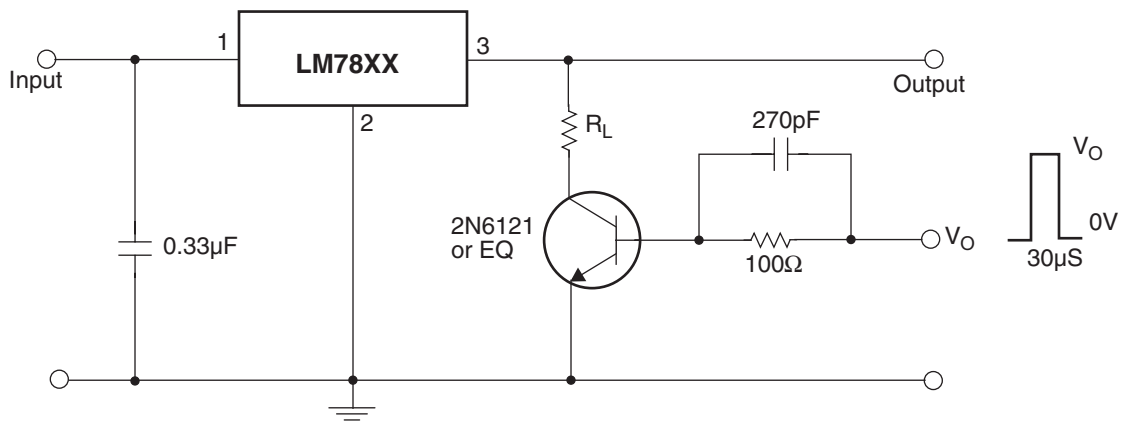

Figure 8. Load Regulation

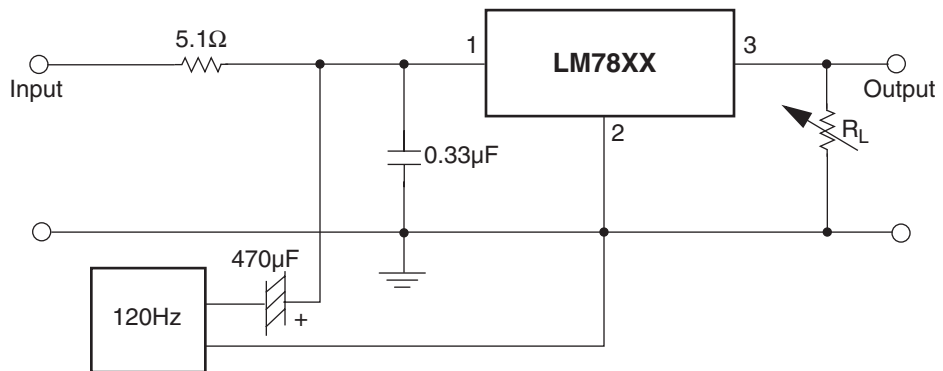

Figure 9. Ripple Rejection

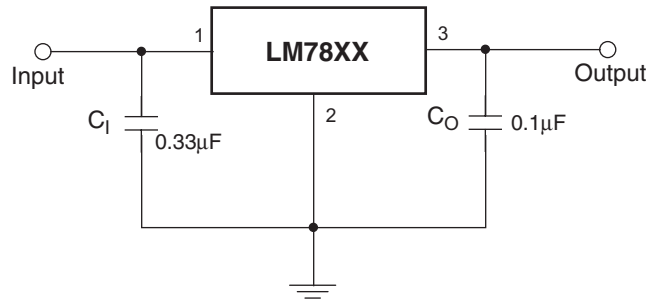
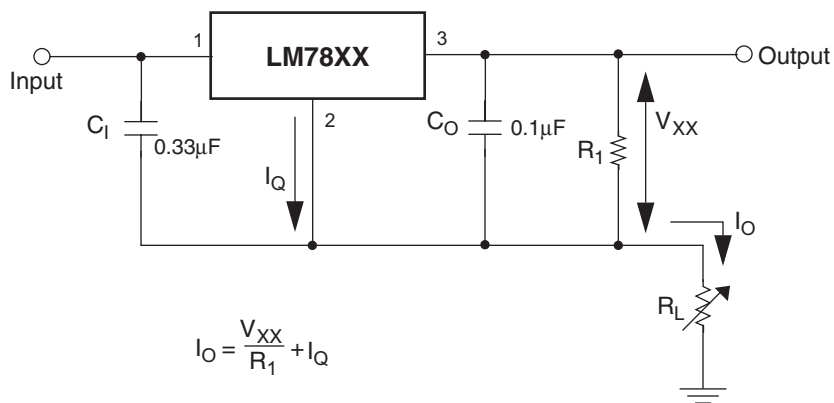

Figure 10. Fixed Output Regulator



Notes:

1. To specify an output voltage, substitute voltage value for "XX." A common ground is required between the input and the output voltage. The input voltage must remain typically 2.0V above the output voltage even during the low point on the input ripple voltage.
2. C₁ is required if regulator is located an appreciable distance from power supply filter.
3. C₀ improves stability and transient response.

Figure 11.

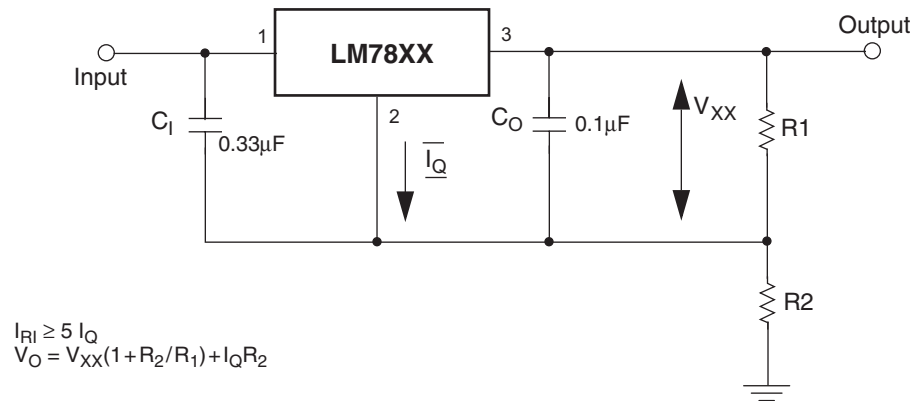

Figure 12. Circuit for Increasing Output Voltage

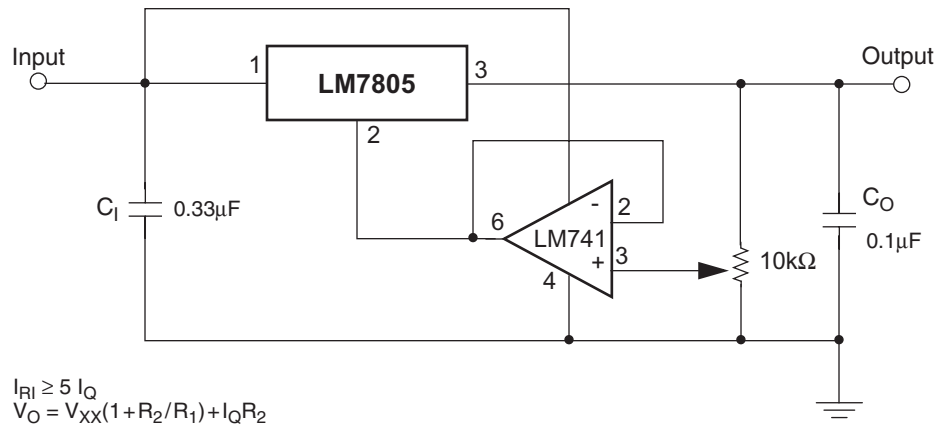

Figure 13. Adjustable Output Regulator (7V to 30V)

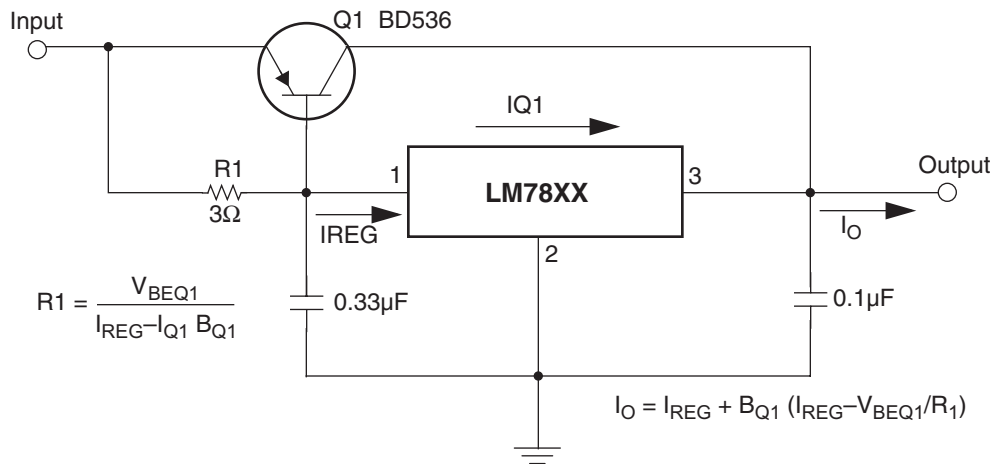

Figure 14. High Current Voltage Regulator

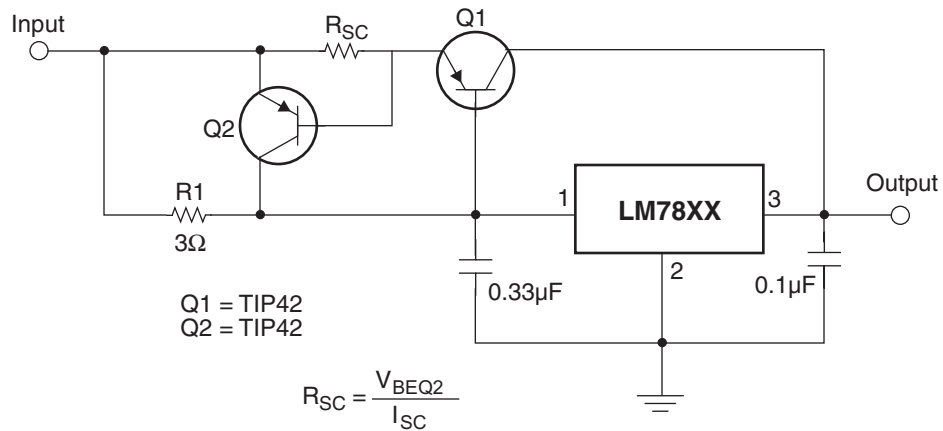

Figure 15. High Output Current with Short Circuit Protection

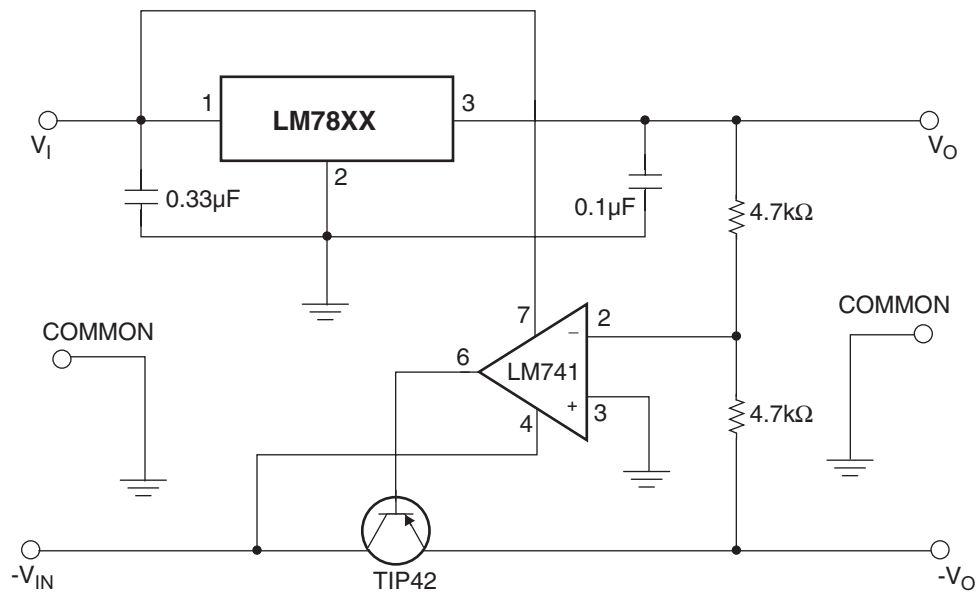

Figure 16. Tracking Voltage Regulator

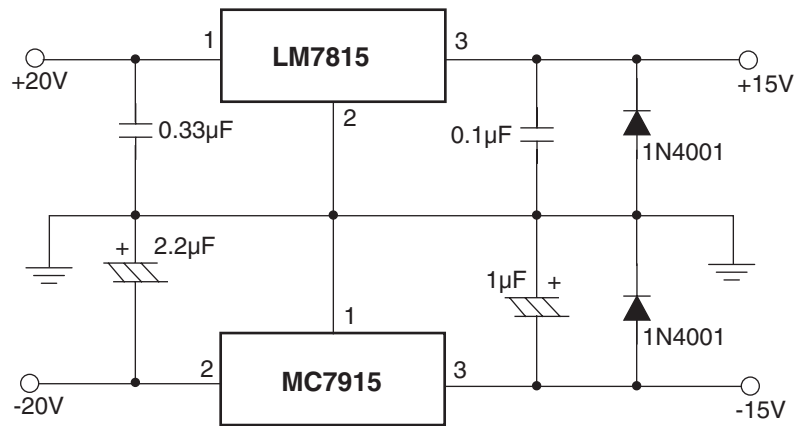

Figure 17. Split Power Supply ($\pm 15V - 1A$)

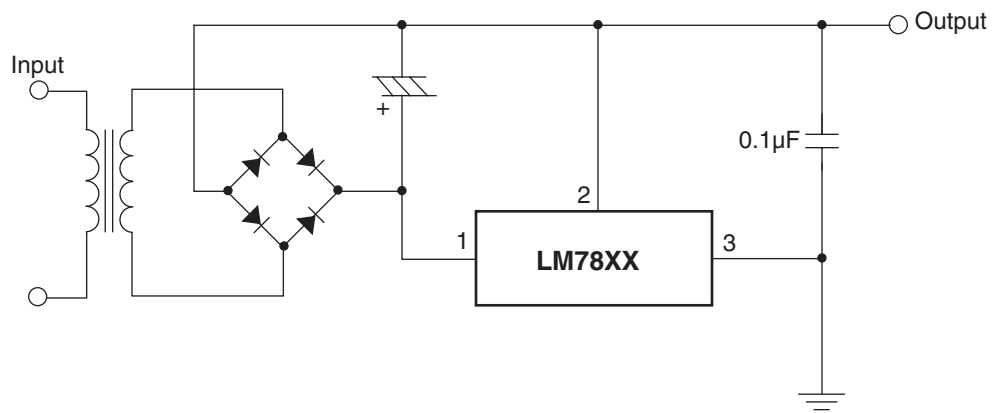

Figure 18. Negative Output Voltage Circuit

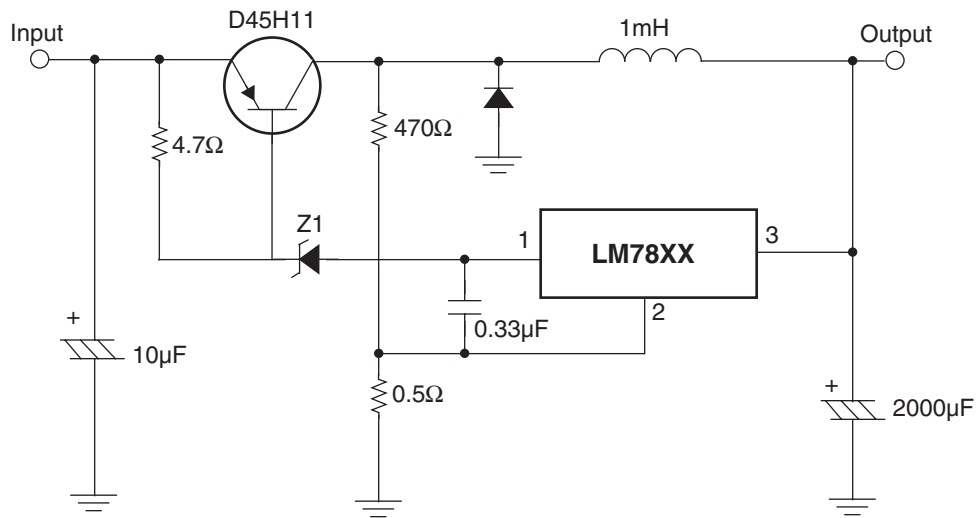
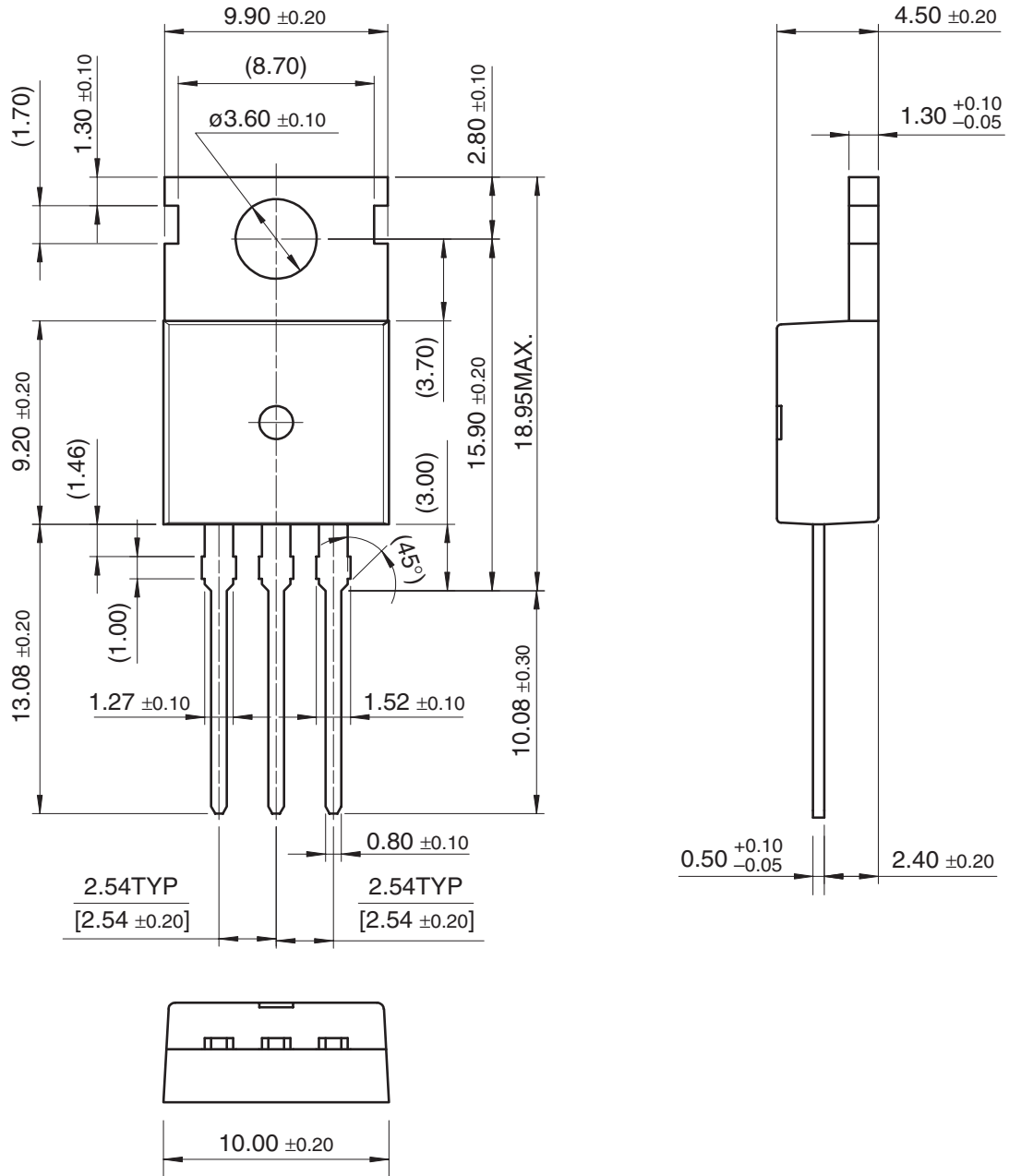

Figure 19. Switching Regulator

Mechanical Dimensions

Dimensions in millimeters

TO-220



TRADEMARKS

The following are registered and unregistered trademarks Fairchild Semiconductor owns or is authorized to use and is not intended to be an exhaustive list of all such trademarks.

ACEx™	FAST®	ISOPLANAR™	PowerEdge™	SuperFET™
ActiveArray™	FASTr™	LittleFET™	PowerSaver™	SuperSOT™-3
Bottomless™	FPS™	MICROCOUPLER™	PowerTrench®	SuperSOT™-6
Build it Now™	FRFET™	MicroFET™	QFET®	SuperSOT™-8
CoolFET™	GlobalOptoisolator™	MicroPak™	QS™	SyncFET™
CROSSVOLT™	GTO™	MICROWIRE™	QT Optoelectronics™	TCM™
DOME™	HiSeC™	MSX™	Quiet Series™	TinyLogic®
EcoSPARK™	I ² C™	MSXPro™	RapidConfigure™	TINYOPTO™
E ² C MOS™	i-Lo™	OCX™	RapidConnect™	TruTranslation™
EnSigna™	ImpliedDisconnect™	OCXPro™	μSerDes™	UHC™
FACT™	IntelliMAX™	OPTOLOGIC®	ScalarPump™	UniFET™
FACT Quiet Series™		OPTOPLANAR™	SILENT SWITCHER®	UltraFET®
Across the board. Around the world.™		PACMAN™	SMART START™	VCX™
The Power Franchise®		POP™	SPM™	Wire™
Programmable Active Droop™		Power247™	Stealth™	

DISCLAIMER

FAIRCHILD SEMICONDUCTOR RESERVES THE RIGHT TO MAKE CHANGES WITHOUT FURTHER NOTICE TO ANY PRODUCTS HEREIN TO IMPROVE RELIABILITY, FUNCTION OR DESIGN. FAIRCHILD DOES NOT ASSUME ANY LIABILITY ARISING OUT OF THE APPLICATION OR USE OF ANY PRODUCT OR CIRCUIT DESCRIBED HEREIN; NEITHER DOES IT CONVEY ANY LICENSE UNDER ITS PATENT RIGHTS, NOR THE RIGHTS OF OTHERS. THESE SPECIFICATIONS DO NOT EXPAND THE TERMS OF FAIRCHILD'S WORLDWIDE TERMS AND CONDITIONS, SPECIFICALLY THE WARRANTY THEREIN, WHICH COVERS THESE PRODUCTS.

LIFE SUPPORT POLICY

FAIRCHILD'S PRODUCTS ARE NOT AUTHORIZED FOR USE AS CRITICAL COMPONENTS IN LIFE SUPPORT DEVICES OR SYSTEMS WITHOUT THE EXPRESS WRITTEN APPROVAL OF FAIRCHILD SEMICONDUCTOR CORPORATION.

As used herein:

1. Life support devices or systems are devices or systems which, (a) are intended for surgical implant into the body, or (b) support or sustain life, or (c) whose failure to perform when properly used in accordance with instructions for use provided in the labeling, can be reasonably expected to result in significant injury to the user.
2. A critical component is any component of a life support device or system whose failure to perform can be reasonably expected to cause the failure of the life support device or system, or to affect its safety or effectiveness.

PRODUCT STATUS DEFINITIONS

Definition of Terms

Datasheet Identification	Product Status	Definition
Advance Information	Formative or In Design	This datasheet contains the design specifications for product development. Specifications may change in any manner without notice.
Preliminary	First Production	This datasheet contains preliminary data, and supplementary data will be published at a later date. Fairchild Semiconductor reserves the right to make changes at any time without notice in order to improve design.
No Identification Needed	Full Production	This datasheet contains final specifications. Fairchild Semiconductor reserves the right to make changes at any time without notice in order to improve design.
Obsolete	Not In Production	This datasheet contains specifications on a product that has been discontinued by Fairchild semiconductor. The datasheet is printed for reference information only.