

Service Manual

Tuner

ST-G90

QUARTZ Synthesizer
AM/FM Stereo Tuner

Color

(K)...Black Type

Area

Color	Area
(K)	(EX).....Continental Europe.
(K)	(EH)Holland.
(K)	(EG)F.R Germany.
(K)	(EI)Italy.
(K)	(XL).....Australia..
(K)	(XA).....Asia, Latin America, Middle Near East, Africa and Oceania.
(K)	(PA).....Far East PX.
(K)	(PE).....European Military.

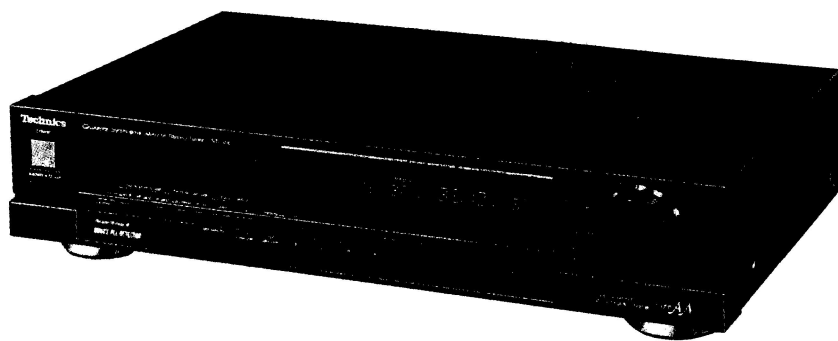

SPECIFICATIONS (DIN 45 500)

■ FM TUNER SECTION

Frequency range	87.50~108.00 MHz
	87.525~108.00 MHz (+25kHz shift)
Sensitivity	1.5 μ V (IHF, usable)
S/N 30dB	1.3 μ V (75 Ω)
S/N 26dB	1.2 μ V (75 Ω)
S/N 20dB	0.9 μ V (75 Ω)
IHF 46dB stereo quieting sensitivity	28 μ V/75 Ω
Total harmonic distortion	
MONO (normal)	0.015%
STEREO (normal)	0.02%
S/N	
MONO	80dB (86dB, IHF)
STEREO	74dB (79dB, IHF)
Frequency response	4Hz~15kHz, +0.5dB~-0.5dB
Alternate channel selectivity	
normal \pm 400kHz	55dB
super narrow \pm 200kHz	30dB
Capture ratio	1.0dB
Image rejection at 98MHz	130dB
IF rejection at 98MHz	130dB
Spurious response rejection at 98MHz	130dB

AM suppression	55dB
Stereo separation	
1kHz	60dB
10kHz	45dB
Carrier leak	
19kHz	-75dB (-80dB, IHF)
38kHz	-75dB (-80dB, IHF)
Channel balance (250Hz~6,300Hz)	\pm 1.0dB
Limiting point	0.85 μ V
Bandwidth	
IF amplifier	180kHz
FM demodulator	1000kHz
Antenna terminals	75 Ω (unbalanced)

■ AM TUNER SECTION

Frequency range	
(For Europe and Australia)	522kHz~1611kHz (9kHz-steps)
	530kHz~1620kHz (10kHz-steps)
(For Others)	531kHz~1602kHz (9kHz-steps)
	530kHz~1600kHz (10kHz-steps)
Sensitivity (S/N 20dB)	20 μ V, 300 μ V/m
Selectivity at 999kHz (\pm 9kHz)	50dB

Technics

Matsushita Electric Industrial Co., Ltd.
 Central P.O. Box 288, Osaka 530-91, Japan

Panasonic Tokyo Office
 Matsushita Electric Trading Co., Ltd.
 6th Floor, World Trade Center Bldg.,
 No. 4-1, Hamamatsu-cho 2-Chome, Minato-ku,
 Tokyo 105, Japan

Image rejection at 999 kHz 40 dB
 IF rejection at 999 kHz 60 dB

GENERAL

Output voltage 0.3V (0.6V IHF)
 Power consumption 9.5W
 Power supply
 For Australia AC 50 Hz/60 Hz, 240V
 For continental Europe AC 50 Hz/60 Hz, 220V
 For others AC 50 Hz/60 Hz, 110V/127V/220V/240V

Dimensions (W × H × D) 430 × 93.5 × 288 mm
 (16-30/32" × 2-22/32" × 9-11/32")
 Weight 3.5 kg (7.7 lb.)

Notes:

1. Total harmonic distortion is measured by the digital spectrum analyzer (H.P. 3045 system).
2. Specifications are subject to change without notice. Weight and dimensions are approximate.

CONTENTS

	Page		Page
CONNECTIONS.....	2	CIRCUIT BOARD AND WIRING	
LOCATION OF CONTROLS.....	3, 4	CONNECTION DIAGRAM.....	17~19
DISASSEMBLY INSTRUCTIONS.....	5	BLOCK DIAGRAM.....	20, 21
MEASUREMENTS AND ADJUSTMENTS.....	6~9	SCHEMATIC DIAGRAM.....	22~27
REPLACEMENT PARTS LIST.....	10, 11	TERMINAL GUIDE OF IC'S,	
RESISTORS & CAPACITORS.....	12~14	TRANSISTORS AND DIODES.....	28
FUNCTION OF TERMINAL		EXPLODED VIEW.....	29, 30
(IC901: M50941-421SP).....	14	REPLACEMENT PARTS LIST.....	31
DESCRIPTION OF FL PANEL.....	16	ACCESSORIES.....	32

CONNECTIONS

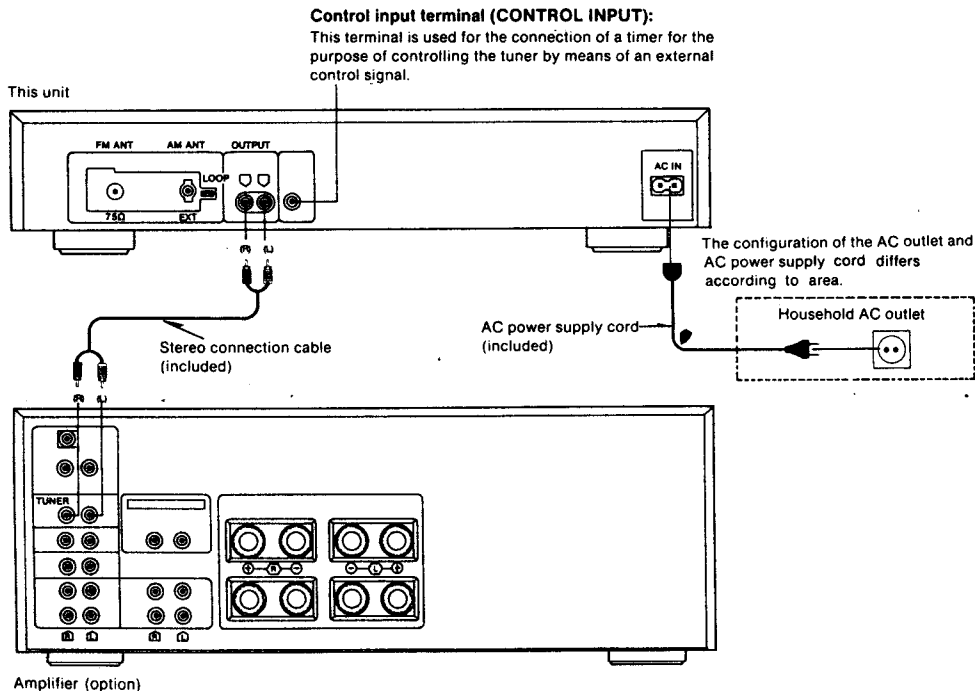

LOCATION OF CONTROLS

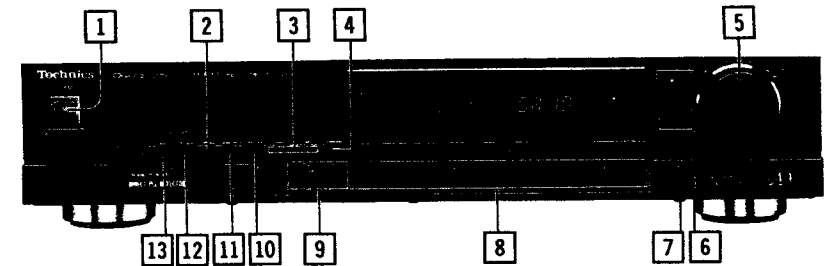

Control section

- 1 Power "standby ϕ /on" switch (power "standby ϕ /on")**
 This switch switches ON and OFF the secondary circuit power only. The unit is in the "standby ϕ " position. Regardless of the switch setting, the primary circuit is always "live" as long as the power cord is connected to an electrical outlet.
- 2 FM IF band selector (IF band)**
 The built-in computer of this unit detects the signal condition and functions accordingly to select the FM IF band automatically. This button is used to change it manually.
- 3 Memory-search button (memory search)**
 This button is used to confirm a memory presetting. If the button is pressed, the memorized frequency and "channel" number will be shown one after the other in order.
- 4 Memory button (memory)**
 This button is used when preset memory setting of the preset-tuning buttons is made.
- 5 Tuning control (tuning)**
 This control is used to select an FM or AM broadcast. When turning the control to the left, the frequency change downward. When turning the control to the right, the frequency change upward.
- 6 Tuning-mode selector/indicator (tuning mode)**
 Each time this selector is pressed, the selection changes, in sequence, to "auto", "manual" and "lock".
auto:
 At this position, broadcast stations are automatically found when the tuning control is turned to the left or right until the frequency changes.
manual:
 At this position, the tuning control can be used to locate the desired station.
lock:
 At this position, the broadcast station now being heard is locked in, and other broadcast stations cannot be tuned to, even if turning the tuning control.
- 7 Scan level selector (scan level)**
 This button is used for setting or confirming the level of the reception signal during automatic FM tuning.
- 8 Preset-tuning buttons (39 channel random preset tuning)**
 These buttons are used to preset FM and AM broadcast frequencies into the memory of this unit, and are also pressed to select the desired preset frequencies.
- 9 Band selectors (band selector)**
FM:
 Press this button to listen to an FM broadcast.
freq shift:
 When the button is pressed slightly longer, the reception frequency increases by 0.025 MHz (25 kHz). (The final figure of the frequency display changes to "2" or "7".)
 In order to return to the original frequency indication, press this button for about 2 seconds again.
AM:
 Press this button to listen to an AM broadcast.
allocation:
 This button is also used to select a frequency step of either 9 kHz or 10 kHz.
 When the AM button is pressed for about 4 seconds, the AM frequency step will change to 10 kHz per step. (This step is set to 9 kHz before shipment.)
 Set to the appropriate position for your locality.
- 10 Recording-level check button (rec level)**
 This button is to be used for adjustment of the recording level when recording an FM broadcast.
 Other operations cannot be performed while the recording-level-check indicator is illuminated.
 To perform other operations, first be sure that the recording-level-check indicator is OFF.

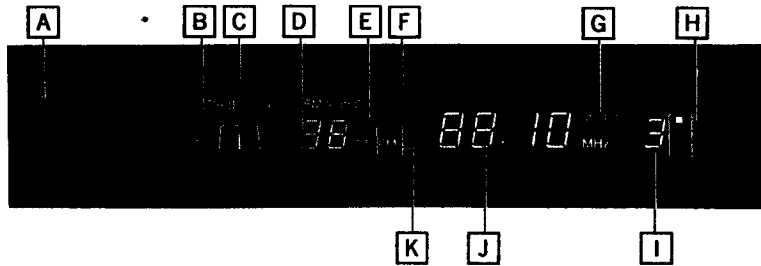

Display section

11 FM mode selector (FM mode)

If noise is excessive in stereo broadcasts, a switchover to monaural reception can be made. When there is a change to monaural reception, the illumination of the FM mode indicator changes to the "mono" position.

12 FM RF-band selector (RF band)

This button can be used to switch the RF bandwidth to either the "normal" width or the "super narrow" width by manual operation.

Interference signals are removed if switched to "super narrow".

13 FM RF-band automatic-selector (auto RF)

It sometimes happens, during the reception of FM broadcasts, that a station other than the desired station is received, or interference noise is excessive, even though there is no broadcast station other than the desired station on a nearby frequency.

The reason for this is that interference signals are produced in a frequency band in which there is actually no broadcast station when two or more strong broadcast stations' signals (interference signals) are input to the unit's "front end" (input stage). These interference signals are known as "cross modulation" interference signals, and they cause interference noise to be heard in the signals from the desired broadcast station.

This model is designed to eliminate such cross modulation interference signals by automatically switching the bandwidth of the RF (radio frequency; high frequency) band to the "super narrow" bandwidth.

- set freq only:

By lightly tapping this selector, the presence or not of interference signals within the broadcast signals being received is detected, and there is an automatic switchover to either the "normal" or "super narrow" circuitry as appropriate.

- all preset ch:

If this selector is pressed and held for a slightly longer time, the presence or not of interference signals within the broadcast signals of all FM broadcast stations that have been preset to the unit's memory is detected. There is then an automatic switchover to either the "normal" or "super narrow" circuitry as appropriate, and then an entry is automatically made (to the memory for these same "channels") of the "normal" or "super narrow" reception condition.

A Quartz-lock indicator (quartz lock)

This indicator illuminates when tuned precisely to an FM or AM station.

B FM RF/IF band indicator (RF/IF band)

These indicators show the FM reception conditions.

C FM RF/IF automatic-select indicator (RF IF auto)

This indicator illuminates when the FM RF-band automatic-selector is pressed.

D FM signal-strength display (FM signal)

This display usually shows the reception level of FM broadcasts (maximum 86 dB); when the scan-level selector is pressed and held, the station-tuning level is displayed in the sequence 30 → 40 → 50.

E Recording-level-check indicator (rec)

F FM stereo indicator (stereo)

This indicator automatically illuminates when an FM stereo broadcast is being received. It will not illuminate if the FM mode selector is set to the monaural mode.

G Memory indicator (memo)

This indicator illuminates when the memory button is pressed.

H FM mode indicator (FM mode)

When FM broadcasts are being received, usually the "auto" indication is illuminated. When the FM mode selector is used to select monaural reception, the illumination of the FM mode indicator changes to the "mono" position.

I Channel display (preset ch)

The channel number selected by the preset-tuning buttons is displayed.

J Digital frequency display

The reception frequency of the FM or AM broadcast selected by using the tuning control or the preset-tuning buttons is indicated.

K Band indicator (band)

DISASSEMBLY INSTRUCTIONS

Ref. No. 1	How to remove the cabinet	Ref. No. 3	How to remove the LED/operation SW RF band selector P.C.B. and tuning VR P.C.B.
Procedure 1	<ul style="list-style-type: none"> Remove the 5 screws (①~⑤). 	Procedure 1 → 2 → 3	<ol style="list-style-type: none"> How to remove the LED/operation SW P.C.B. <ul style="list-style-type: none"> Remove the 8 screws (①~⑧). How to remove the RF band selector P.C.B. <ul style="list-style-type: none"> Remove the 3 screws (②~④). How to remove the tuning VR P.C.B. <ul style="list-style-type: none"> Remove the tuning VR with hexagonal wrench. Remove the nut.
Ref. No. 2	How to remove the main P.C.B. and power supply P.C.B.	Ref. No. 4	How to remove the quartz lock LED P.C.B.
Procedure 1 → 2	<ol style="list-style-type: none"> How to remove the main P.C.B. <ul style="list-style-type: none"> Remove the 3 screws (①~③). Remove the 2 tabs and the front panel. Remove the 8 screws (④~⑧). How to remove the power supply P.C.B. <ul style="list-style-type: none"> Remove the 5 screws (⑨~⑬). 	Procedure 1 → 2 → 4	<ul style="list-style-type: none"> Remove the 2 tabs.

MEASUREMENTS AND ADJUSTMENTS

AM/FM

Control positions and equipment used

- AM and FM signal generator (AM and FM-SG)
- Stereo modulator
- Distortion analyser
- Oscilloscope
- Frequency counter

- Choke coil (100 μ H)
- Resistor (100k Ω)
- Ceramic capacitor (200pF)
- AC and DC electronic voltmeter (EVM)

Note: For L301, L302 (L.P.F.) and L303 (L.P.F.), they are supplied as adjusted parts. So, do not turn the cores of the parts.

AM-IF ADJUSTMENT

1. Test equipment connection is shown in figure.
2. Set the to "AM" mode.
3. Set the radio frequency display and signal generator to 450kHz.
4. Adjust T201 for maximum output.

AM SIGNAL GENERATOR CONDITION
Modulation30%
Modulation frequency400Hz

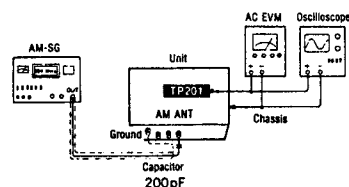

AM-RF ADJUSTMENT

1. Test equipment connection is shown in figure (1).
2. Set the unit to "AM" mode.
3. Set the radio frequency display and signal generator to 522kHz.
4. Adjust L204 so that the voltage measured in signal mode is 1.0V.
5. Test equipment connection is shown in figure (2).
6. Set the radio frequency display and signal generator to 612kHz.
7. Adjust L203 for maximum output.
8. Set the radio frequency display and signal generator to 1503kHz.
9. Adjust CT201 for maximum output.
10. Repeat steps 6-9.

AM SIGNAL GENERATOR CONDITION
Modulation30%
Modulation frequency400Hz

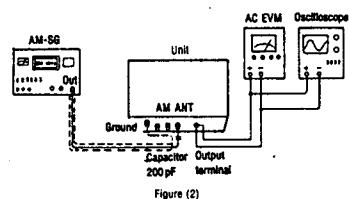

FM-RF ADJUSTMENT

1. Test equipment connection is shown in figure.
2. Set the unit to "FM and RF narrow" mode.
3. Set the radio frequency display and signal generator to 90.1MHz.
4. Adjust L1, L2 and L4 for maximum output.
5. Set the radio frequency display and signal generator to 106.1MHz.
6. Adjust CT1, CT2 and CT3 for maximum output.
7. Repeat steps 5 and 6.

FM SIGNAL GENERATOR CONDITION
Modulation100%
Modulation frequency1kHz

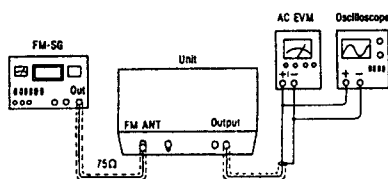

MPX VCO ADJUSTMENT

1. Test equipment connection is shown in figure.
2. Set the unit to "on/auto" position.
3. Set the radio frequency display and signal generator to 100.10MHz.
4. Adjust VR302 for 19kHz \pm 30Hz on frequency counter reading.

USING ALTERNATE SYSTEM

1. Apply stereo signal from generator or receive the stereo broadcast.
2. Adjust VR302 until stereo indicator lights up. Fix the arm of VR302 as shown in figure.

FM SIGNAL GENERATOR CONDITION

Modulation0%
Modulation frequency0
Output level66dB

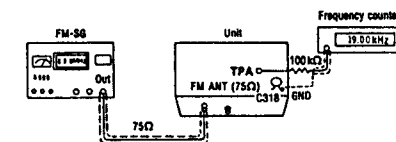

TPA = TP301, Frequency counter: 19.00 kHz

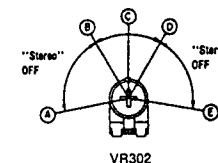
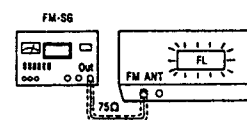

- Ⓐ-ⓐ..... "Stereo" OFF position
- ⓑ-ⓑ..... "Stereo" ON position (Indicator lighting)
- ⓒ..... Adjust point of pilot circuit

FM DETECTION CIRCUIT ADJUSTMENT

1. Test equipment connection is shown in figure.
2. Set the unit to "FM and normal" mode.
3. Set the radio frequency display and signal generator to 100.10MHz.
4. Adjust the core of T101 so that the voltage measured in signal mode is 0mV in 300mV range. (Fig. (1))
5. Adjust T102 for maximum output. (Fig. (2))
6. Adjust the core of T103 so that the voltage measured in signal mode is 0mV in 300mV range. (Fig. (2))
7. Adjust VR104 for maximum (+) on DC voltmeter reading.
8. Set the FM signal generator condition to STEREO L+R, 1kHz 90%, PILOT 10% mode.
9. Adjust the core of T103 so that the voltage measured in signal mode is 0mV in 300mV range. (Fig. (2))

FM SIGNAL GENERATOR CONDITION
Modulation100%
Modulation frequency1kHz
Output level66dB

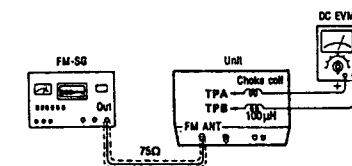

TPA = TP101, TPB = TP102

Fig. (1)

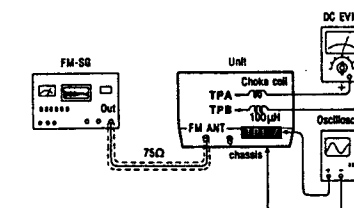

TPA = TP105, TPB = TP106

Fig. (2)

FM STEREO DISTORTION ADJUSTMENT

1. Test equipment connection is shown in figure.
2. Set the unit to "FM and normal" mode.
3. Set the radio frequency display and signal generator to 100.10 MHz.
4. Adjust T1 so that the distortion factor of L-CH is minimized.
5. Make sure that the distortion factors of L-CH and R-CH are nearly the same with each other to minimum.
6. Set the unit to "IF narrow" mode.
7. Adjust T104 so that the distortion factor of L-CH is minimized.
8. Make sure that the distortion factors of L-CH and R-CH are nearly the same with each other to minimum.

- Note:** 1. The adjusting screwdriver used should be made of resin.
2. T1 should be rotated no more 1/4 turn (90 deg.) on either side.
 3. T104 should be rotated no more 1/6 turn (60 deg.) on either side.

FM SIGNAL GENERATOR CONDITION

Modulation "L" mode or "R" mode 45%,
Pilot 10%
Modulation frequency 1 kHz (Pilot 19 kHz)
Output level 68 dB

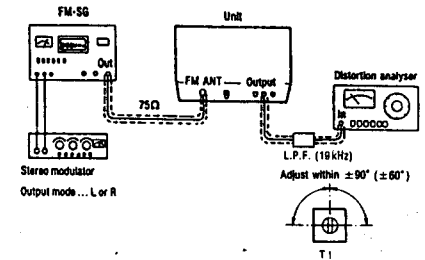
**SEPARATION ADJUSTMENT**

1. Test equipment connection is shown in figure.
2. Set the unit to "FM and normal" mode.
3. Set the radio frequency display and signal generator to 100.10 MHz.
4. Adjust VR303 so that the R-CH output is minimized when stereo modulator is in "L" (L-CH modulation) mode.
5. Adjust VR304 so that the L-CH output is minimized when stereo modulator is in "R" (R-CH modulation) mode.

FM SIGNAL GENERATOR CONDITION

Modulation "L" mode or "R" mode 45%,
Pilot 10%
Modulation frequency 1 kHz (Pilot 19 kHz)
Output level 68 dB

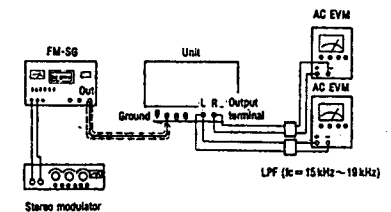
**FM SIGNAL STRENGTH LEVEL ADJUSTMENT**

1. Test equipment connection is shown in figure.
2. Set the unit to "FM and normal" mode.
3. Set the radio frequency display and signal generator to 100.10 MHz.
4. Change LCD display from "frequency" to "dB" by pressing the FM signal button.
5. Adjust VR103 so that 50 dB is indicated. "50 dB" is indicated on the LCD display.
6. Adjust VR102 so that 70 dB is indicated. "70 dB" is indicated on the LCD display.
7. Adjust VR101 so that 86 dB is indicated. "86 dB" is indicated on the LCD display.
8. Repeat steps 5~7.

FM SIGNAL GENERATOR CONDITION

Modulation 30%
Modulation frequency 1 kHz
Output level 56, 76, 92 dB

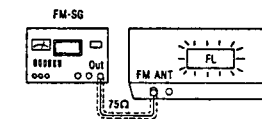

Ref. No.	Part No.	Description	Ref. No.	Part No.	Description
VR105	EYND4A00B14	V.R. FM IF NARROW	(EX, EH, XL)		
VR302	EYND4A00B63	V.R. MPX VCO	(XA, PA, PE)		
VR303	EYND4A00B15	V.R. SEPARATION			
VR304	EYND4A00B15	V.R. SEPARATION			
VR901	EYQW9S2512B	V.R. TUNING			
VARIABLE CAPACITORS					
CT1	ECRH4007A41	TRIMMER			
CT2	ECRH4007A41	TRIMMER			
CT3	ECRH4007A41	TRIMMER			
CT201	SVCT203110F	TRIMMER			
THERMISTORS AND VARISTORS					
TH1	ERT022HL333S	THERMISTOR			
TH101	ERT022HL332S	THERMISTOR			
TH103	ERT022HL333S	THERMISTOR			
COILS AND TRANSFORMERS					
L1	SLA4P81	FM ANT COIL			
L2	SLD4P81	COIL			
L3	SLQAN40G1-P	CHOKO COIL			
L4	SLD4P81	COIL			
L101	RLQZP3R3KT-Y	COIL			
L102	ELEXT101KA9	COIL			
L103	ELEXT101KA9	COIL			
L104	ELEXT101KA9	COIL			
L105	ELEXT101KA9	COIL			
L106	ELEXT101KA9	COIL			
L107	ELEXT101KA9	COIL			
L203	SLA2B1-1M	ANTENNA COIL			
L204	SL02B7-M	OSCILLATOR COIL			
L301	SLM1B1-P	MPX COIL			
(EG, E1)					
L302	SLM5B2-1P	MPX COIL			
L303	SLM5B2-1P	MPX COIL			
L304	RLQZP4K7KT-Y	CHOKO COIL			
L305	RLQZP4K7KT-Y	CHOKO COIL			
L701	SLQZ65DM49	CHOKO COIL			
(EG, E1)					
L901	RLQZP3R3KT-Y	COIL			
L902	RLQZP3R3KT-Y	COIL			
L903	RLQZP2R2KT-Y	COIL			
T101	SL14B515-Z	I.F. TRANSFORMER			
T102	SL14B525-P	I.F. TRANSFORMER			
T103	SL14B525-P	I.F. TRANSFORMER			
T104	SL14B109-Z	I.F. TRANSFORMER			
T201	SL12B103-M	I.F. TRANSFORMER			
T701	SLT5K248	POWER TRANSFORMER			
(EX, EH, EG)					
(E1)					
T701	SLT5K248	POWER TRANSFORMER			
(XL)					
T701	SLT5K250	POWER TRANSFORMER			
(XA, PA, PE)					
FILTERS					
CF101	SVFE107M22-L	CERAMIC FILTER			
(EX, EH, XL)					
(XA, PA, PE)					
CF101	SVFE107M22-L	CERAMIC FILTER			
(EG, E1)					
CF102	SVFE107M22-L	CERAMIC FILTER			
RELAYS					
RL1	SFDYG5A237P	RELAY			
RL2	SFDYG5A237P	RELAY			
RL201	SFDYG5A237P	RELAY			

RESISTORS & CAPACITORS

Notes : * Important safety notice : Components identified by Δ mark have special characteristics important for safety. When replacing any of these components use only manufacturer's specified parts.
* Bracketed indications in Ref. No. columns specify the area. (Refer to the first page for area.) Parts without these indications can be used for all areas.

Numbering System of Resistor

Example:

ERD	25	F	J	102
Type	Wattage (1/4W)	Shape	Tolerance	Value (1K Ω)
ERX	2	AN	J	471
Type	Wattage (2W)	Shape	Tolerance	Value (470 Ω)

Numbering System of Capacitor

Example:

ECKD	1H	102	Z	F
Type	Voltage (50V)	Value (0.001 μ F)	Tolerance	Peculiarity
ECEA	50	M	330	
Type	Voltage (50V)	Peculiarity	Value (33 μ F)	

● Capacity are in microfarads (μ F) unless specified otherwise, P = Pico-farads (pF) F = Farads (F).
● Resistance are in ohms (Ω), unless specified otherwise, 1K = 1,000 Ω , 1M = 1,000k Ω .

Resistor Type	Wattage	Tolerance	
ERD : Carbon	10 : 1/8W	12 : 1/2W	J : $\pm 5\%$
ERG : Metal Oxide	14 : 1/4W	25 : 1/4W	F : $\pm 1\%$
ERQ : Fuse Type Metal	18 : 1/8W	18 : 1/8W	G : $\pm 2\%$
ERX : Metal Film	52 : 1/4W	51 : 1/2W	J : $\pm 5\%$
ERD L : Carbon (chip)	2F : 1/4W	50 : 1/2W	K : $\pm 10\%$
ERD K : Metal Film (chip)	2A : 2W	3A : 3W	M : $\pm 20\%$
ERC : Solid	6G : 1/10W	8G : 1/8W	
ERF : Incombustible Box-Shaped			
ERM : Wire-Wound			
ERJ : Chip Resistor			
ERL : Chip Resistor			

Capacitor Type	Voltage	Tolerance	
ECE : Electrolytic	6J : 6.3V	1A : 10V	K : $\pm 10\%$
ECCD : Ceramic	1C : 16V	1E : 25V	M : $\pm 20\%$
ECKD : Ceramic Capacitor	1H : 50V	1V : 55V	Z : +80%
ECOM : Polyester	50 : 50V	05 : 50V	-20
ECOP : Polypropylene	2H : 500V	2A : 100V	J : $\pm 5\%$
ECG : Ceramic	1 : 100V	1J : 63V	G : $\pm 2\%$
ECEA N : Non Polar Electrolytic	KC : 400V AC		F : $\pm 1\%$
OCU : Ceramic (Chip Type)	KC : 125V AC		C : $\pm 0.25\mu$ F
ECUX : Ceramic (Chip Type)	(UL)		D : $\pm 0.5\mu$ F
ECF : Semiconductor			
ECCW : Liquid electrolyte double layer capacitor			



Ref. No.	Part No.	Value.	Ref. No.	Part No.	Value.	Ref. No.	Part No.	Value.
RESISTORS (VALUE, WATTAGE)								
R1	ERDS2TJ104	100K 1/4	R133	ERDS2TJ471	470 1/4	R183	ERDS2TJ331	330 1/4
R2	ERDS2TJ273	27K 1/4	R134	ERDS2TJ682	6.8K 1/4	(EG, E1)		
R3	ERDS2TJ104	100K 1/4	R135	ERDS2TJ183	18K 1/4	R201	ERDS2TJ473	47K 1/4
R4	ERDS2TJ104	100K 1/4	R136	ERDS2TJ684	680K 1/4	R202	ERDS2TJ222	2.2K 1/4
R5	ERDS2TJ104	100K 1/4	R137	ERDS2TJ473	47K 1/4	R203	ERDS2TJ563	56K 1/4
R6	ERDS2TJ823	82K 1/4	R138	ERDS2TJ472	4.7K 1/4	R204	ERDS2TJ222	2.2K 1/4
R7	ERDS2TJ103	10K 1/4	R139	ERDS2TJ331	330 1/4	R205	ERDS2TJ101	100 1/4
R8	ERDS2TJ100	10 1/4	R140	ERDS2TJ222	2.2K 1/4	R206	ERDS2TJ473	47K 1/4
R9	ERDS2TJ104	100K 1/4	R141	ERDS2TJ102	1K 1/4	R207	ERDS2TJ123	12K 1/4
R10	ERDS2TJ820	82 1/4	R142	ERDS2TJ222	2.2K 1/4	(EG, E1)		
R11	ERDS2TJ820	82 1/4	R143	ERDS2TJ102	1K 1/4	R207	ERDS2TJ562	5.6K 1/4
R12	ERDS2TJ820	82 1/4	R144	ERDS2TJ102	1K 1/4	(EX, EH, XL)		
R101	ERDS2TJ820	82 1/4	R145	ERDS2TJ102	1K 1/4	(XA, PA, PE)		
R102	ERDS2TJ472	4.7K 1/4	R146	ERDS2TJ102	1K 1/4	R208	ERDS2TJ104	100K 1/4
R103	ERDS2TJ562	5.6K 1/4	R147	ERDS2TJ104	100K 1/4	R209	ERDS2TJ102	1K 1/4
R104	ERDS2TJ331	330 1/4	R148	ERDS2TJ104	100K 1/4	R210	ERDS2TJ682	6.8K 1/4
R105	ERDS2TJ331	330 1/4	R149	ERDS2TJ104	100K 1/4	R211	ERDS2TJ473	47K 1/4
R106	ERDS2TJ331	330 1/4	R150	ERDS2TJ101	100 1/4	R212	ERDS2TJ101	100 1/4
R107	ERDS2TJ561	560 1/4	R151	ERDS2TJ472	4.7K 1/4	R213	ERDS2TJ473	47K 1/4
R108	ERDS2TJ123	12K 1/4	R152	ERDS2TJ182	1.8K 1/4	R214	ERDS2TJ104	100K 1/4
R109	ERDS2TJ103	10K 1/4	R153	ERDS2TJ122	1.2K 1/4	R301	ERDS2TJ104	100K 1/4
R110	ERDS2TJ472	4.7K 1/4	R154	ERDS2TJ102	1K 1/4	R302	ERDS2TJ104	100K 1/4
R111	ERDS2TJ321	320 1/4	R155	ERDS2TJ273	27K 1/4	R304	ERDS2TJ103	10K 1/4
R112	ERDS2TJ103	10K 1/4	R156	ERDS2TJ103	10K 1/4	(EX, EH, XL)		
R113	ERDS2TJ151	150 1/4	R157	ERDS2TJ820	82 1/4	(XA, PA, PE)		
R114	ERDS2TJ681	680 1/4	R158	ERDS2TJ224	220K 1/4	R304	ERDS2TJ273	27K 1/4
R115	ERDS2TJ322	3.2K 1/4	R159	ERDS2TJ474	470K 1/4	(EG, E1)		
R116	ERDS2TJ322	3.2K 1/4	R160	ERDS2TJ223	22K 1/4	R305	ERDS2TJ104	100K 1/4
R117	ERDS2TJ322	3.2K 1/4	R161	ERDS2TJ223	22K 1/4	R306	ERDS2TJ682	6.8K 1/4
R118	ERDS2TJ322	3.2K 1/4	R162	ERDS2TJ683	68K 1/4	R307	ERDS2TJ333	33K 1/4
R119	ERDS2TJ321	320 1/4	R163	ERDS2TJ473	47K 1/4	R308	ERDS2TJ103	10K 1/4
R120	ERDS2TJ102	1K 1/4	R164	ERDS2TJ473	47K 1/4	R309	ERDS2TJ123	12K 1/4
R121	ERDS2TJ222	2.2K 1/4	R165	ERDS2TJ103	10K 1/4	(EX, EH, XL)		
R122	ERDS2TJ331	330 1/4	R166	ERDS2TJ103	10K 1/4	(XA, PA, PE)		
R123	ERDS2TJ272	2.7K 1/4	R167	ERDS2TJ223	22K 1/4	R309	ERDS2TJ223	22K 1/4
R124	ERDS2TJ331	330 1/4	R168	ERDS2TJ182	1.8K 1/4	(EG, E1)		
R125	ERDS2TJ103	10K 1/4	(EG, E1)			R310	ERDS2TJ563	56K 1/4
R126	ERDS2TJ472	4.7K 1/4	R175	ERDS2TJ332	3.3K 1/4	R311	ERDS2TJ472	4.7K 1/4
R129	ERDS2TJ382	3.8K 1/4	(EX, EH, XL)			R312	ERDS2TJ103	10K 1/4
R130	ERDS2TJ221	220 1/4	(XA, PA, PE)			R314	ERDS2TJ820	82 1/4
R131	ERDS2TJ101	100 1/4	R176	ERDS2TJ332	3.3K 1/4	R315	ERDS2TJ473	47K 1/4
R132	ERDS2TJ104	100K 1/4	R177	ERDS2TJ563	56K 1/4	R316	ERDS2TJ473	47K 1/4
			R178	ERDS2TJ473	47K 1/4	R317	ERDS2TJ153	15K 1/4

Ref. No.	Part No.	Value.	Ref. No.	Part No.	Value.	Ref. No.	Part No.	Value.
R318	ERDS2T.J392	3.9K 1/4	R704	ERDS2T.J101	100 1/4	C121	RCBS1H8DJCY	18P 50
R319	ERDS2T.J223	22K 1/4	R707	ERDS2T.J222	2.2K 1/4	C122	ECQM1H22JZ	0.0012 50
R320	ERDS2T.J103	10K 1/4	R708	ERDS2T.J222	2.2K 1/4	C123	ECKD1H103PF	0.01 50
R321	ERDS2T.J183	18K 1/4	R710	ERDS2T.J391	390 1/4	C124	ECKD1H103PF	0.01 50
R322	ERDS2T.J393	39K 1/4	R711	ERDS2T.J472	4.7K 1/4	C125	RCBS1H6R8KCY	6.8P 50
R323	ERDS2T.J153	15K 1/4	R713	ERDS2T.J101	100 1/4	C126	ECQM1H223JZ	0.022 50
(EX, EH, XL)			R714	ERDS2T.J101	100 1/4	C127	ECEAJJ101	100 6.3
(XA, PA, PE)			R715	ERDS2T.J470	47 1/4	C128	ECEAHK010	1 50
R324	ERDS2T.J692	6.8K 1/4	R716	ERDS2T.J470	47 1/4	C129	ECKD1H103PF	0.01 50
(EG, E1)			R901	ERDS2T.J692	6.8K 1/4	C130	ECQM1H223JZ	0.022 50
R324	ERDS2T.J153	15K 1/4	R902	ERDS2T.J123	12K 1/4	C131	ECKD1H103PF	0.01 50
(EX, EH, XL)			R903	ERDS2T.J102	1K 1/4	C132	ECKD1H103PF	0.01 50
(XA, PA, PE)			R904	ERDS2T.J691	680 1/4	C133	ECKD1H103PF	0.01 50
R324	ERDS2T.J692	6.8K 1/4	R906	ERDS2T.J472	4.7K 1/4	C134	ECKD1H103PF	0.01 50
(EG, E1)			R908	ERDS2T.J123	12K 1/4	C135	ECKD1H103PF	0.01 50
R325	ERDS2T.J333	33K 1/4	R911	ERDS2T.J102	1K 1/4	C136	ECFTD104KXL	0.1 25
R326	ERDS2T.J333	33K 1/4	R912	ERDS2T.J102	1K 1/4	C137	RCBS1H300JLY	30P 50
R327	ERDS2T.J153	15K 1/4	R913	ERDS2T.J104	100K 1/4	C138	ECQP1471JZ	470P 125
R328	ERDS2T.J153	15K 1/4	R914	ERDS2T.J104	100K 1/4	C139	RCBC1H470JLY	47P 50
R329	ERDS2T.J101	100 1/4	R915	ERDS2T.J104	100K 1/4	C140	RCBC1H470JLY	47P 50
R330	ERDS2T.J101	100 1/4	R916	ERDS2T.J104	100K 1/4	C141	RCBS1H6R8KCY	6.8P 50
R331	ERDS2T.J102	1K 1/4	R917	ERDS2T.J691	680 1/4	C142	ECBT1H471K95	470P 50
R332	ERDS2T.J102	1K 1/4	R918	ERDS2T.J103	10K 1/4	(EG, E1)		
R333	ERDS2T.J331	330 1/4	R919	ERDS2T.J103	10K 1/4	C142	RCBC1H101K95	100P 50
R334	ERDS2T.J331	330 1/4	R920	ERDS2T.J104	100K 1/4	(EX, EH, XL)		
R335	ERDS2T.J332	3.3K 1/4	R921	ERDS2T.J103	10K 1/4	(XA, PA, PE)		
R336	ERDS2T.J332	3.3K 1/4	R922	ERDS2T.J105	1M 1/4	C143	ECQM1H122JZ	0.0012 50
R337	ERDS2T.J222	2.2K 1/4	R923	ERDS2T.J102	1K 1/4	C144	RCBS1H10DJCY	10P 50
R338	ERDS2T.J222	2.2K 1/4	R924	ERDS2T.J102	1K 1/4	C145	RCBC1H470JLY	47P 50
R341	ERDS2T.J104	100K 1/4	R925	ERDS2T.J104	100K 1/4	C146	ECQP1102JZ	0.001 100
R341	ERDS2T.J592	5.6K 1/4	R926	ERDS2T.J104	100K 1/4	C147	ECEA1CJ221	220 16
R342	ERDS2T.J592	5.6K 1/4	R927	ERDS2T.J473	47K 1/4	C148	ECKD1H103PF	0.01 50
R343	ERDS2T.J223	22K 1/4	R928	ERDS2T.J473	47K 1/4	C149	ECKD1H103PF	0.01 50
R344	ERDS2T.J223	22K 1/4	R929	ERDS2T.J153	15K 1/4	C150	ECKD1H103PF	0.01 50
(EX, EH, XL)			R930	ERDS2T.J181	180 1/4	C151	RCBS1H6R8KCY	6.8P 50
(XA, PA, PE)			R931	ERDS2T.J471	470 1/4	C152	ECFTD104KXL	0.1 25
R344	ERDS2T.J593	59K 1/4	R932	ERDS2T.J181	180 1/4	C153	ECBT1H102K95	0.001 50
(EG, E1)			R933	ERDS2T.J221	220 1/4	C154	ECBT1H102K95	0.001 50
R345	ERDS2T.J273	27K 1/4	CAPACITORS(VALUE,VOLTAGE)			C155	RCBS1H300JLY	39P 50
(EX, EH, XL)			C1	ECEA1VK3R3	3.3 35	C156	RCBC1H470JLY	47P 50
(XA, PA, PE)			C2	ECBT1H102K95	0.001 50	C201	ECKD1H103PF	0.01 50
R345	ERDS2T.J333	33K 1/4	C3	ECBT1H102K95	0.001 50	C202	ECEAJK330	33 6.3
(EG, E1)			C4	RCBS1H390JLY	39P 50	C203	ECKD1H103PF	0.01 50
R346	ERDS2T.J104	100K 1/4	C5	ECQ9R22K	0.22 500	C204	ECEA1HKR47	0.47 50
R347	ERDS2T.J333	33K 1/4	C9	RCBS1H4R7KCY	4.7P 50	C205	ECEAJK330	33 6.3
(EG, E1)			C10	ECKD1H102MDL	0.001 50	C206	ECKD1H223PF	0.022 50
R347	ERDS2T.J693	69K 1/4	C11	ECBT1H102K95	0.001 50	C207	ECFTD104KXL	0.1 25
(EX, EH, XL)			C12	ECBT1H102K95	0.001 50	(EX, EH, XL)		
(XA, PA, PE)			C15	ECBT1H102K95	0.001 50	(XA, PA, PE)		
R348	ERDS2T.J102	1K 1/4	C16	ECQM1H223JZ	0.022 50	(EG, E1)		
(EG, E1)			C17	ECKD1H103PF	0.01 50	C207	ECQM1H473JZ	0.047 50
R348	ERDS2T.J183	18K 1/4	C18	ECEA1VK100B	10 35	(EG, E1)		
(EX, EH, XL)			C19	ECBT1H102K95	0.001 50	C208	ECKD1H223PF	0.022 50
(XA, PA, PE)			C21	RCBS1H1R0MICY	1P 50	C209	RCBC1H220JLY	22P 50
R349	ERDS2T.J333	33K 1/4	C22	ECQM1H223JZ	0.022 50	C210	ECQP1471JZ	470P 125
R350	ERDS2T.J333	33K 1/4	C23	ECKD1H103PF	0.01 50	C211	ECKD1H223PF	0.022 50
R351	ERDS2T.J561	560 1/4	C101	ECKD1H103PF	0.01 50	C212	ECKD1H103PF	0.01 50
R352	ERDS2T.J823	82K 1/4	C102	ECKD1H103PF	0.01 50	C213	ECKD1H103PF	0.01 50
R353	ERDS2T.J333	33K 1/4	C103	ECBT1H102K95	0.001 50	C301	ECEA1HK010	1 50
R354	ERDS2T.J332	3.3K 1/4	C104	ECEA1HKR22	0.22 50	C303	ECQM1H472JZ	0.0047 50
R355	ERDS2T.J471	470 1/4	C105	ECKD1H103PF	0.01 50	C304	ECBT1H102K95	0.001 50
R356	ERDS2T.J102	1K 1/4	C106	ECKD1H103PF	0.01 50	C305	ECBT1H621K95	820P 50
R357	ERDS2T.J102	1K 1/4	C107	ECKD1H103PF	0.01 50	C306	ECEA1CJ221	220 16
R358	ERDS2T.J223	22K 1/4	C108	ECKD1H103PF	0.01 50	C307	ECEAJJ101	100 6.3
R359	ERDS1F.J121	120 1/2	C109	ECKD1H103PF	0.01 50	C308	ECQM1H152JZ	0.0015 50
R360	ERDS2T.J104	100K 1/4	C110	ECKD1H103PF	0.01 50	(EX, EH, EG)		
R361	ERDS2T.J473	47K 1/4	C111	ECKD1H103PF	0.01 50	(E1, XL, XA)		
(EG, E1)			C112	ECKD1H103PF	0.01 50	C308	ECQM1H222JZ	0.0022 50
R361	ERDS2T.J692	6.8K 1/4	C113	ECKD1H103PF	0.01 50	(PA, PE)		
(EX, EH, XL)			C114	ECBT1H102K95	0.001 50	C309	ECQM1H152JZ	0.0015 50
(XA, PA, PE)			C115	ECEA1HKR22	0.22 50	(EX, EH, EG)		
R362	ERDS1F.J121	120 1/2	C116	ECEAJJ101	100 6.3	(E1, XL, XA)		
R363	ERDS2T.J123	12K 1/4	C117	ECEA1VK100B	10 35	C309	ECQM1H222JZ	0.0022 50
(EX, EH, XL)			C118	ECEAJJ101	100 6.3	(PA, PE)		
(XA, PA, PE)			C119	ECQM1H223JZ	0.022 50	C310	ECEA1VK3R3	3.3 35
R363	ERDS2T.J153	15K 1/4	C120	ECQM1H122JZ	0.0012 50	C311	ECEA1VK100B	10 35
(EG, E1)						C312	ECEA1CJ221	220 16
						C313	ECEA1HKR47	0.47 50

Ref. No.	Part No.	Value.	Ref. No.	Part No.	Value.	Ref. No.	Part No.	Value.
C314	ECEA25MR7R	4.7 25	C708	ECEA1CJ221	220 16	C314	ECEAJUJ71	470 6.3
C315	ECQP1391JZ	350P 100	C710	ECKD1H103PF	0.01 50	C315	ECBT1H102KB5	0.001 50
C316	ECEA1H0K10	1 50	C711	ECEA1VU470	47 35	C316	ECEA1VK100B	10 35
C317	ECFTD104XL	0.1 25	C712	ECEAJUJ101	100 6.3	C317	ECEAJUJ101	100 6.3
C318	ECKD1H103PF	0.01 50	C713	ECEA1VU101	100 35	C318	ECEAJUJ102	1000 6.3
C319	ECEA1VK100B	10 35	C714	ECKD2H102ZF	0.001 500	C319	ECKD1H103PF	0.01 50
C320	ECEA1VK100B	10 35	C715	ECEA1VU101	100 35	C320	ECEAJUJ222	2200 6.3
C323	ECQM1H272JZ	0.0027 50	C716	ECEA1VK100B	10 35	C321	RCBC1H101KBY	100P 50
C324	ECQP1391JZ	350P 100	C717	ECEA1VK3R3	3.3 35	C323	RCBC1H101KBY	100P 50
C327	ECQM1H332JZ	0.0033 50	C718	ECEA1VU470	47 35	C324	RCBC1H101KBY	100P 50
C328	ECQM1H332JZ	0.0033 50	C719	ECEA1VU470	47 35	C325	RCBC1H101KBY	100P 50
C329	ECKD1H103PF	0.01 50	C720	ECKD2H102ZF	0.001 500	C326	RCBC1H101KBY	100P 50
(EG, E1)			C721	ECKD2H102ZF	0.001 500	C327	RCBC1H101KBY	100P 50
C330	RCBC1H101KBY	100P 50	C722	ECEAJUJ71	470 6.3	C328	RCBC1H101KBY	100P 50
(EG, E1)			C302	ECKD1H103PF	0.01 50	C329	ECEA1VK3R3	3.3 35
C701	ECKD2H102ZF	0.001 500	C303	ECKD1H103PF	0.01 50	C300	ECKD1H103PF	0.01 50
C702	ECKD1H103PF	0.01 50	C304	ECKD1H103PF	0.01 50	C301	ECEA1HKR47	0.47 50
C703	ECKD2H102ZF	0.001 500	C305	ECEA25MR7R	4.7 25	C304	RCBC1H101KBY	100P 50
C704	ECEA1CJ222	2200 16	C311	RCBS1H180JCY	18P 50	C305	RCBC1H101KBY	100P 50
C705	ECEA1CJ222	2200 16	C312	RCBS1H150JCY	15P 50	C306	ECEAJK300	33 6.3
C707	ECEA1HKR47	0.47 50	C313	RCBC1H101KBY	100P 50	C307	ECEA1VK100B	10 35

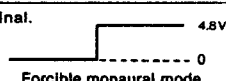
FUNCTION OF TERMINAL (IC901: M50941-421SP)

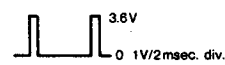
PIN NO.	IN/OUT	MARK	DESCRIPTION OF TERMINAL
1	INPUT	VREF	Reference voltage terminal.
2	—	NC	Not used in this unit.
3	INPUT	A	Tuning volume up/down control terminal.
4		B	
5 6 7	INPUT	SSL1 SSL3	FM signal level detector terminal.
8	INPUT	SD	Station detection of auto tuning terminal. • Received: "H", No signal: "L"
9	INPUT	STEREO	Stereo signal detection terminal. • Stereo: "L", Monaural: "H"
10 17	OUTPUT	TUNING 0 TUNING 1	Tuning mode LED (auto/manual/lock) drive terminal.
11	OUTPUT	RF BAND	FM RF BAND selector terminal. • "normal": "L", "super narrow": "H"
12	OUTPUT	IF BAND	FM IF BAND selector terminal. • "normal": "L", "super narrow": "H"
13	—	NC	Not used in this unit.
14	OUTPUT	REC	REC carribration (333Hz) signal terminal. • REC switch ON: "H", REC switch OFF: "L"
15	OUTPUT	MONO	Forcible monaural selection terminal. 

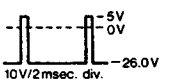
PIN NO.	IN/OUT	MARK	DESCRIPTION OF TERMINAL
16	OUTPUT	MUTE	Terminal to eliminate shock noise due to unlocking at PLL. (Muting output) • Pin 25 (CE) is "L"→"H" or "H"→"L" • Power switch "off". • Frequency change. (up/down, FM→AM (MW/LW), REC). • FM RF/IF selection.
18	OUTPUT	SRDY	PLL data output terminal. SRDY: serial I/O enable signal, CLK: clock signal, SOUT: serial data signal.
19		CLK	
20		SOUT	
21	INPUT	SIN	Control input terminal.
22	OUTPUT	T1	Clock pulse waveform output terminal. • FM: 1kHz signal (duty 50%)
23	OUTPUT	T2	Clock pulse waveform output terminal. • REC "ON": 333Hz signal (duty 50%)
24	INPUT	INT1	Remote control input terminal. Not used in this unit.
25	INPUT	INT2	Power supply detection terminal.
26 32	—	Vss	Ground terminal.
27	INPUT	RESET	Reset signal terminal.
28	INPUT	XIN	Connecting terminal for crystal oscillator.
29	OUTPUT	XOUT	
30	—	XCIN	Not used in this unit.
31	—	XCOUT	
33	—	NC	
34 37	INPUT	R0 R3	Terminal for key return signal to external key matrix. 
38	INPUT	VP	Power supply terminal for FL display.
39 54	OUTPUT	S0 S15	Segment signal terminal for FL display. 
55	—	NC	Not used in this unit.
56 62	OUTPUT	T1 T7	Terminal for key scan signal to external key matrix and grid signal terminal for FL display. 
63	INPUT	AVcc	Power supply terminal of device.
64	INPUT	Vcc	

DESCRIPTION OF FL PANEL

GRID ASSIGNMENT

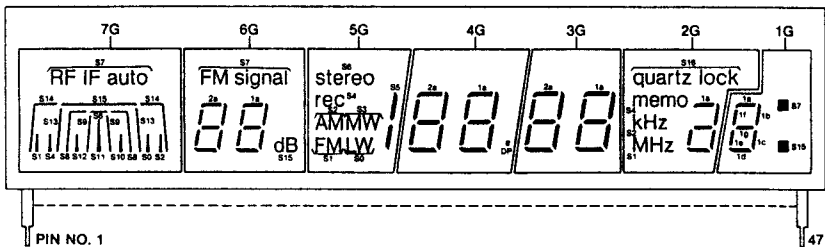

PIN NO.	1	2	3	4	5	6	7	8	9	10	11	12	13	14	15	16	17	18	19	20	21	22	23	24	
CONNECT-ION	N	F	N	7	S	S	S	S	10	S	7	S	S	6	S	N	N	6	N	N	5	N	N	N	N
PIN NO.	25	26	27	28	29	30	31	32	33	34	35	36	37	38	39	40	41	42	43	44	45	46	47		
CONNECT-ION	N	N	N	N	4	S	3	S	S	3	S	S	2	S	S	2	S	1	S	1	N	F	N	N	
	P	P	P	P	G	0	G	1	2	G	3	4	G	5	6	G	16	G	7	G	P	2	P	P	

ANODE ASSIGNMENT

	7G	6G	5G	4G	3G	2G	1G
S0		2d	LW	2d	2d	-	-
S1		2e	FM	2e	2e	MHz	-
S2		2c	AM	2c	2c	kHz	-
S3	-	2g	MW	2g	2g	-	-
S4		2f	rec	2f	2f	memo	-
S5	-	2b	/	2b	2b	-	-
S6	—	2a	stereo	2a	2a	-	-
S7	RF IF auto	FM signal	-	-	-	-	■
S8	∩	1d	-	1d	1d	1d	1d
S9	/ \	1e	-	1e	1e	1e	1e
S10		1c	-	1c	1c	1c	1c
S11		1g	-	1g	1g	1g	1g
S12		1f	-	1f	1f	-	1f
S13	/ \	1b	-	1b	1b	1b	1b
S14	∩	1a	-	1a	1a	1a	1a
S15	—	dB	-	DP	-	-	■
S16	-	-	-	-	-	quartz lock	-

1

2

3

4

5

CIRCUIT BOARDS AND WIRING CONNECTION DIAGRAM

A

A MAIN P.C.B.

FM ANT. (75 Ω) (GND)
 AM ANT. (EXT) (LOOP)
 OUTPUT (R ch) (L ch)
 CONTROL INPUT
 FM detection circ. TP105 TP106

B

C

D

E

F

G

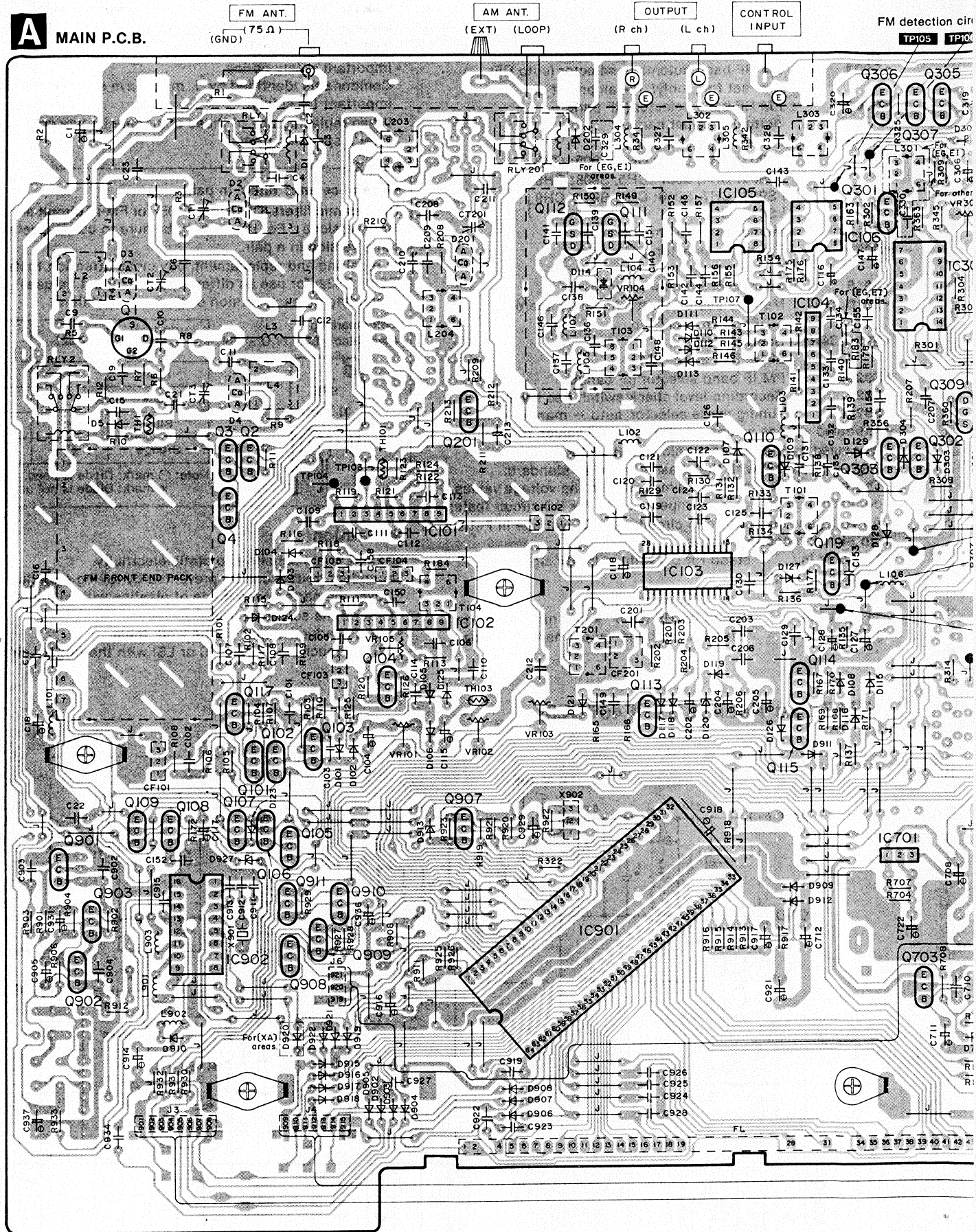

M

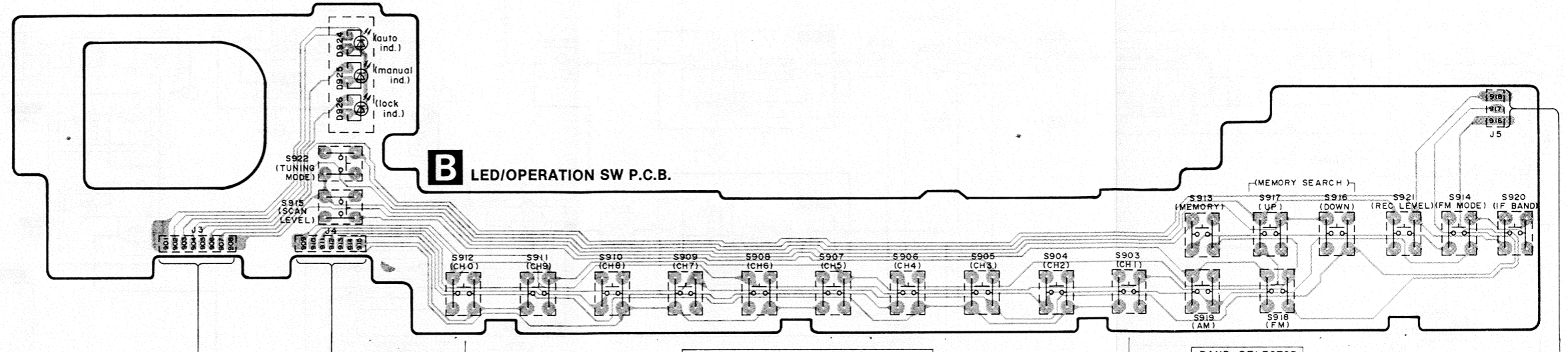
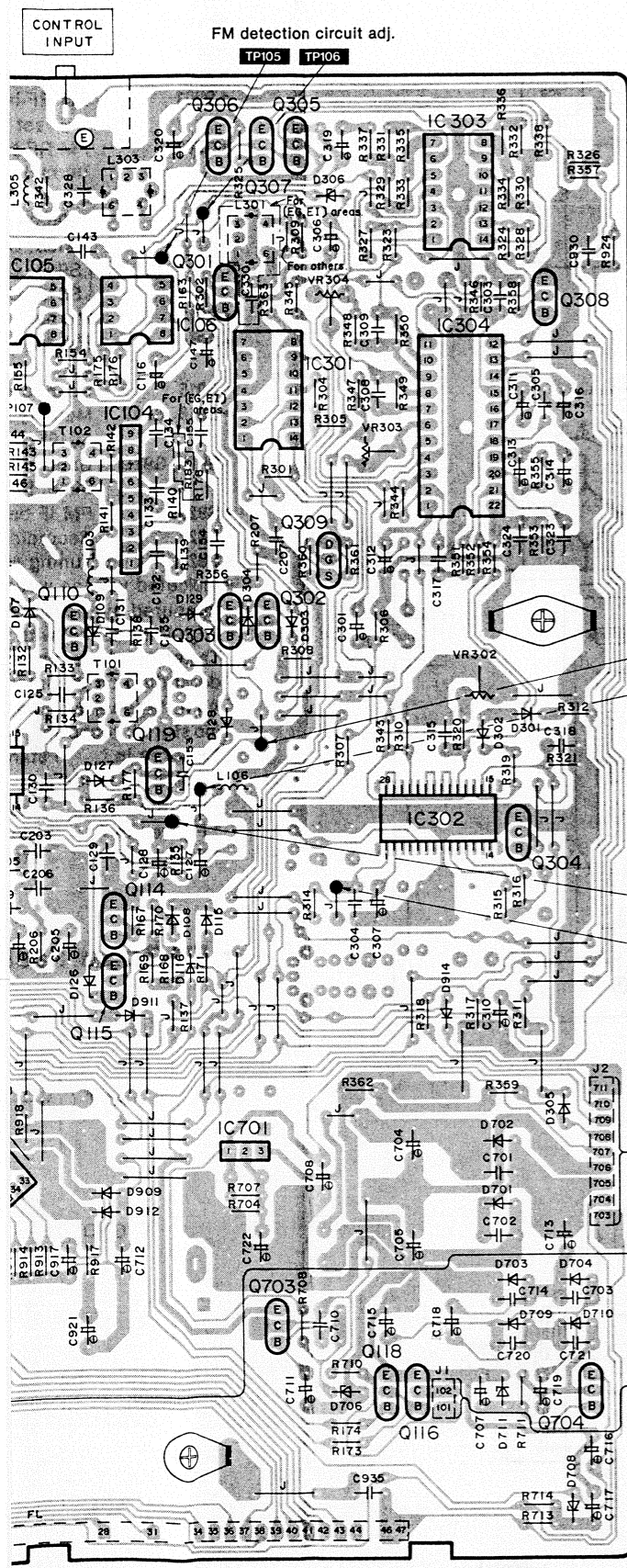

B LED/OPERATION SW P.C.B.

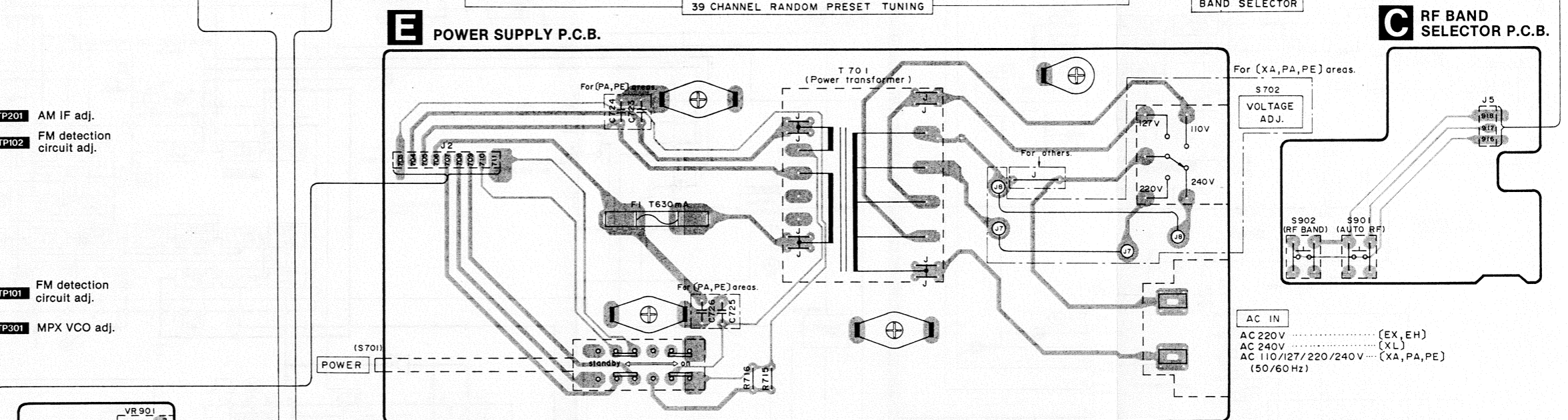

E POWER SUPPLY P.C.B.

C RF BAND SELECTOR P.C.B.

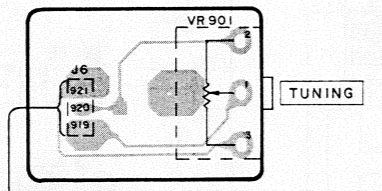

D TUNING VR P.C.B.

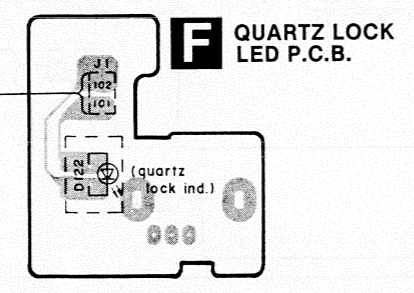

F QUARTZ LOCK LED P.C.B.

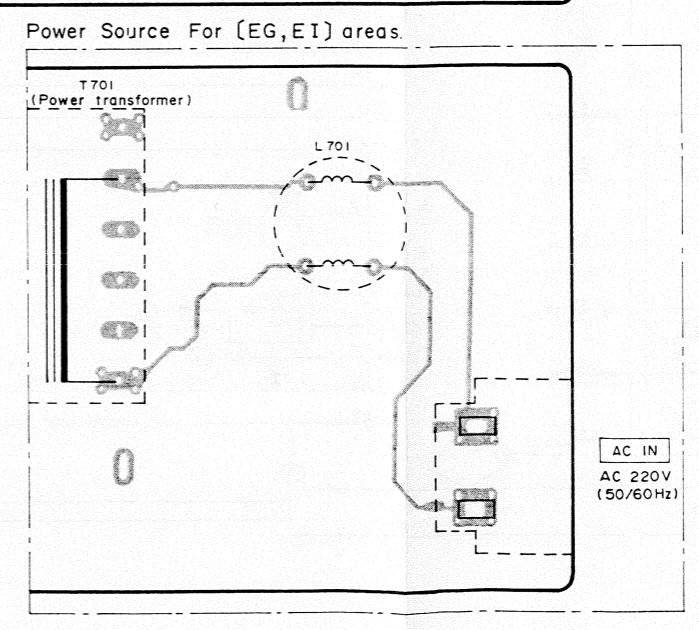

Power Source For (EG, EI) areas.

BLOCK DIAGRAM

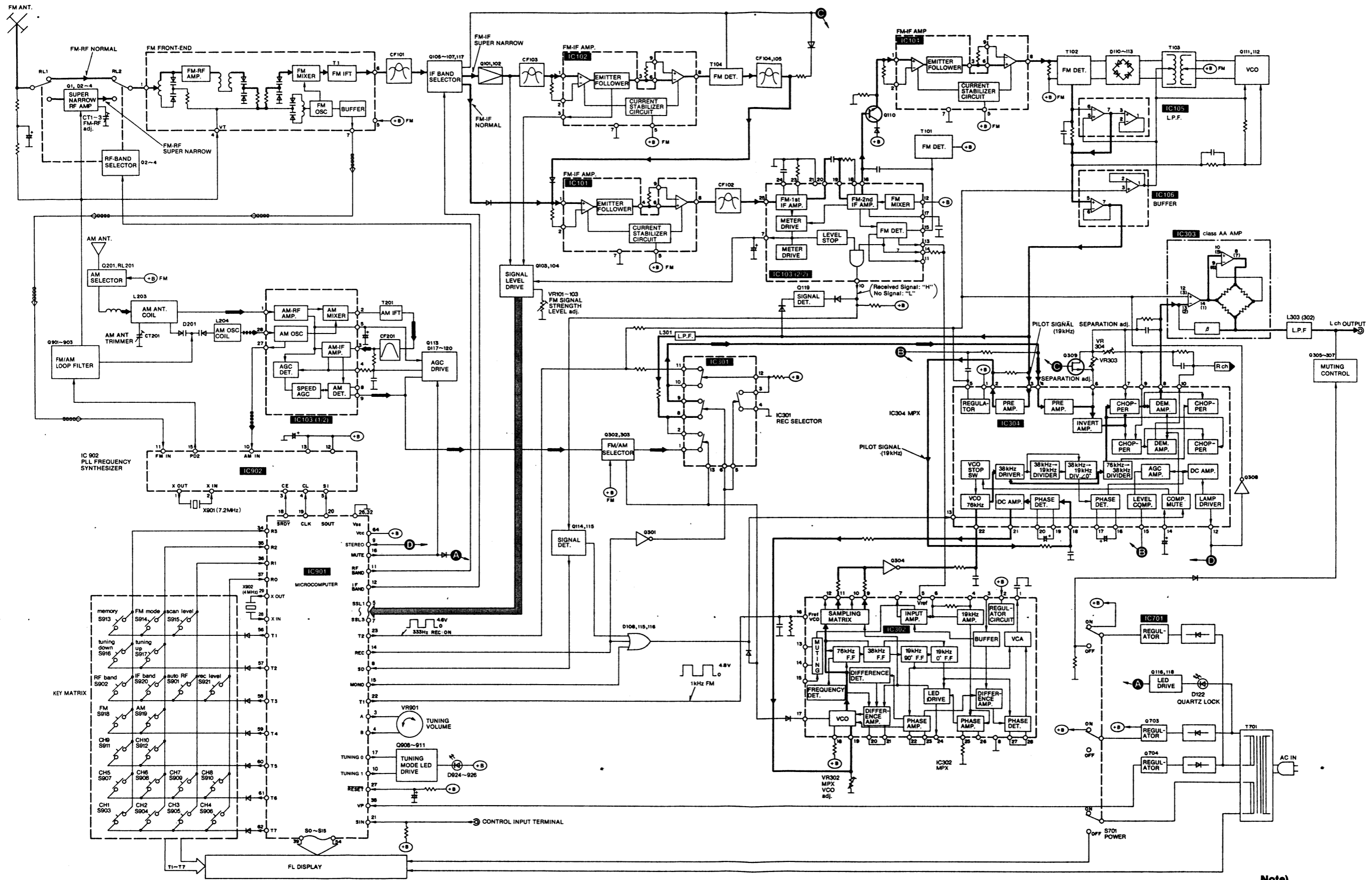

Note)

- → FM signal
- □ □ □ □ → FM OSC
- □ □ □ □ → AM signal
- □ □ □ □ → AM OSC

SCHEMATIC DIAGRAM

(This schematic diagram may be modified at any time with the development of new technology.)

Note 1:

- S701 : Power switch in "ON" position.
- S702 : Voltage selector. (For [XA, PA, PE] areas.)
- S901 : FM RF-band automatic-selector (auto RF).
 — set freq. only/ — all preset ch
- S902 : FM RF-band selector (RF band).
 normal ↔ super narrow
- S903~S912: Preset tuning switch.
 { S903: CH1, S904: CH2, S905: CH3 }
 { S906: CH4, S907: CH5, S908: CH6 }
 { S909: CH7, S910: CH8, S911: CH9 }
 S912: CH0
- S913 : Memory switch. (memory).
- S914 : FM mode selector (FM mode).
 auto ↔ mono
- S915 : Scan level selector (scan level).
- S916, S917 : Memory search switch (memory search).
 S916: down, S917: up
- S918, S919 : Band selectors.
 S918: FM, S919: AM
- S920 : FM IF band selector (IF band).
- S921 : Recording level check switch (rec level).
- S922 : Tuning mode selector auto ↔ manual ↔ lock
- Indicated voltage values are the standard values for the unit measured by the DC electronic circuit tester (high-impedance) with the chassis taken as standard. Therefore, there may exist some errors in the voltage values, depending on the internal impedance of the DC circuit tester. All voltage values shown in circuitry are DC voltage in FM signal (no signal) reception modes.
- * Figures in () stand for DC voltage in AM signal reception mode.
- * Figures in [] stand for muting mode.
- * Figures in < > stand for RF band "super narrow" mode.
- * Figures in ≪ ≫ stand for IF band "super narrow" mode.

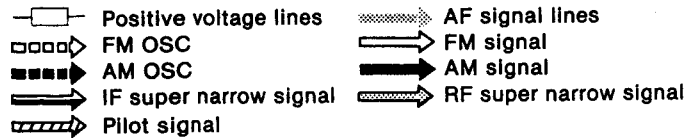

• Important safety notice.
 Components identified by Δ mark have special characteristics important for safety.
 When replacing any of these components, use only manufacturer's specified parts.

Note 2:

• Use of ceramic filters in pairs

The ceramic filters (CF101~CF105) for FM-IF circuit are available in three versions. For this circuit, be sure to use the ceramics of the same version in a pair.

At repairing and replacement, pay close attention to the diodes (D921, D922) for use as different diodes must be used depending on each version of the ceramic filters.

Color marking (Red, Black, Blue, or Orange)

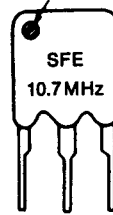

VERSION (Color)	D921	D922
Red	x	x
Black	○	x
Blue	x	○
Orange	○	○

Note: ○ mark: Diode is used.
 x mark: Diode is not used.

*** Caution!**

- IC and LSI are sensitive to static electricity. Secondary trouble can be prevented by taking care during repair.
- Cover the parts boxes made of plastics with aluminum foil.
- Ground the soldering iron.
- Put a conductive mat on the work table.
- Do not touch the legs of IC or LSI with the fingers directly.

• FM Tuner Pack (SNVFE407G29)

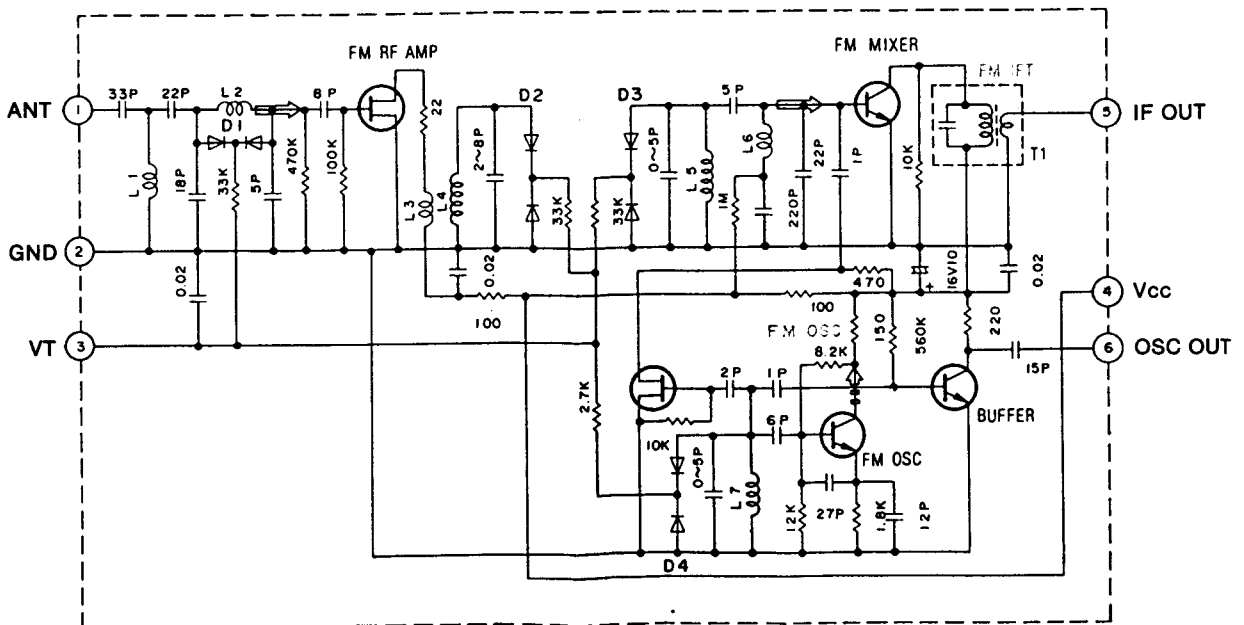

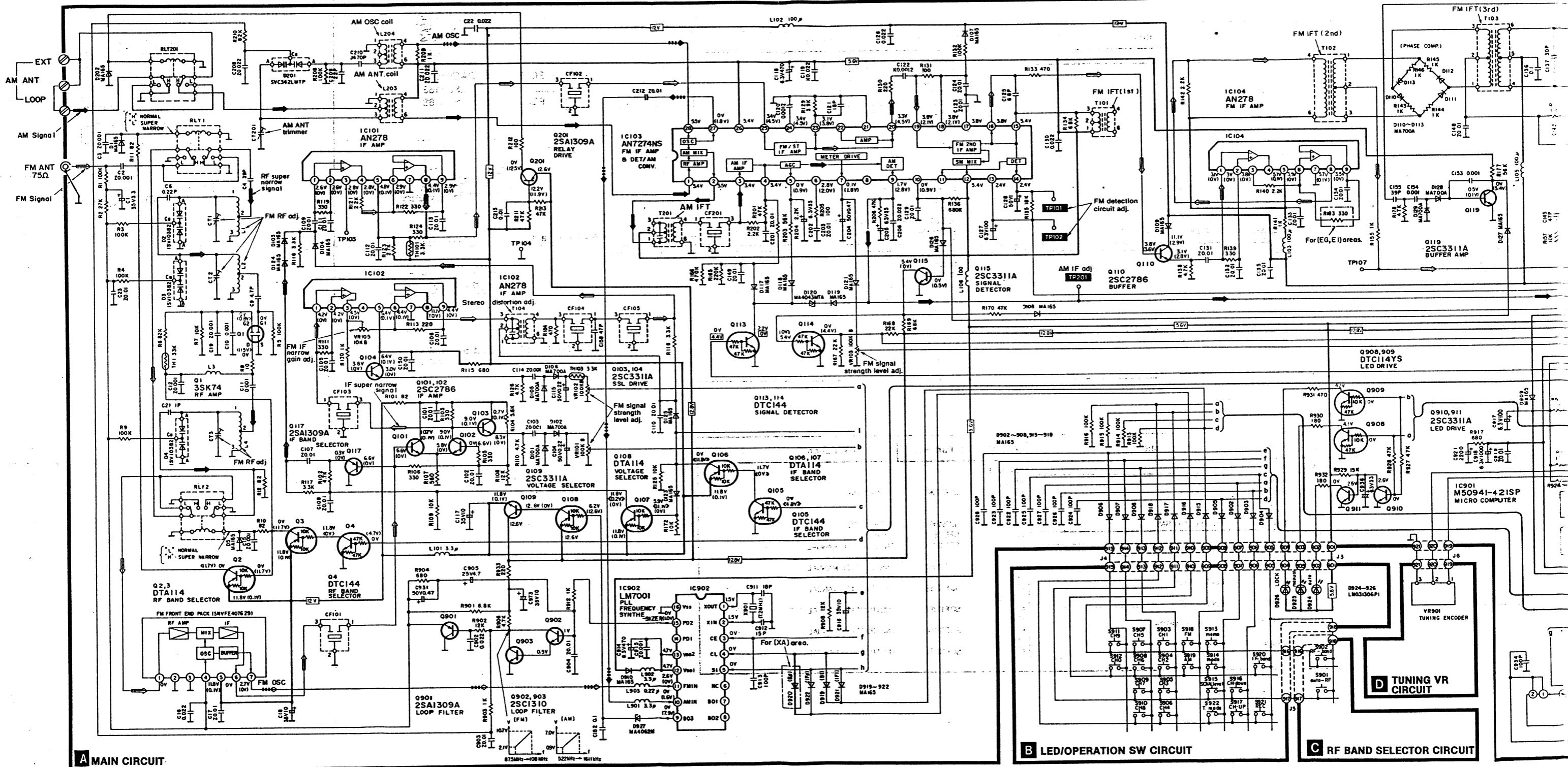

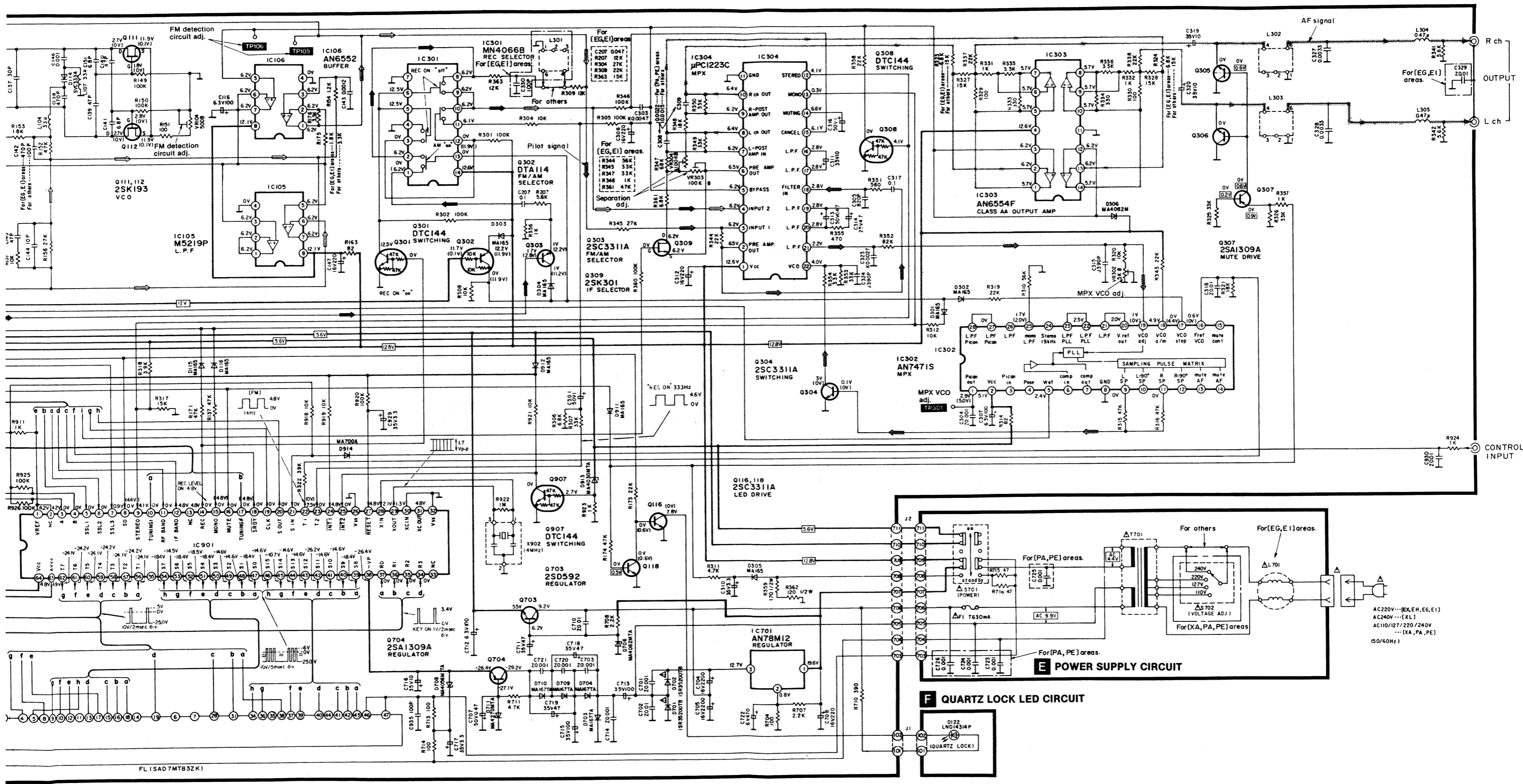

FL (SAD7MT83ZK)

REPLACEMENT PARTS LIST

Notes : * Important safety notice :
 Components identified by Δ mark have special characteristics important for safety. When replacing any of these components use only manufacturer's specified parts.
 * Bracketed indications in Ref. No. columns specify the area. (Refer to the first page for area.)
 Parts without these indications can be used for all areas.

Ref. No.	Part No.	Description	Ref. No.	Part No.	Description
CABINET AND CHASSIS					
1	SGPD613KY2F	CHASSIS	18	SNE2129-1	SCREW
(E1)			19	SJS50780WL	CONNECTOR
1	SGPTG90-KE	CHASSIS	19	SJS50800WL	CONNECTOR
(EX)			20	SJT30340LX-V	CONNECTOR(3P)
1	SGPTG90-KH	CHASSIS	21	SJT390	FUSE HOLDER
(EH, EG)			22	SJF8615NP	TERMINAL BOARD
1	SGPTG90-KL	CHASSIS	(EX, EH, EG)		
(XL)			22	SJF8714NP	TERMINAL BOARD
1	SGPTG90-KX	CHASSIS	(XL, XA, PA)		
(XA, PA, PE)			(PE)		
2	SKL306	INSULATOR	23	SGX7924	ORNAMENT
3	SDU332-1B	FL FILTER	24	QTS1596	SHIELD BOARD
4	SBC096-5	BUTTON, POWER	25	SMC1283	SHIELD COVER
5	SUB183	ROD	26	SJS9236	AC INLET
6	SGX7975	ORNAMENT	27	Δ SJT31747WL	TERMINAL PLATE
7	SHE186-1	SPACER	27	SJT30947WL	CONNECTOR
8	SHE187-2	HOLDER	29	SGL266	INDICATOR
9	SGWT030KEX	FRONT PANEL ASSY	30	SBC1022	BUTTON
10	SUG995	SPRING	31	SBC959	BUTTON
(EG, E1, PA)			32	SBC963D	BUTTON
(PE)			33	SUS870	SPRING
11	XTBS3-HJFZ1	SCREW	34	SLM3113	HOLDER
12	XTB96G	SCREW	36	SHP984	PLASTIC SPACER
13	XTM94T	SCREW	36	SGX7925-1	BRACKET
14	XTBS3-16F1	SCREW	39	XTB3-10G	SCREW
15	XTBS3-20F1	SCREW	40	SUS1007	COIL SPRING
16	SBN123T	KNOB	41	SNE4021	NUT
17	SKC0511KE1	CABINET BODY	42	SMX1001	SHIELD COVER
			43	SGW420T008	ORNAMENT

Ref. No.	Part No.	Description	Ref. No.	Part No.	Description
PACKING MATERIAL					
P1	SPG6248	CARTON BOX	(XL, XA, PA)		
P2	SPS069-2	PAD	(PE)		
P3	SPS070-2	PAD	A3	SSA270M	FM ANTENNA
P4	SPPT65	PROTECTION COVER	(EX, EH, EG)		
P5	XZB23X20003	PROTECTION BAG	(E1)		
ACCESSORIES					
A1	Δ SFDAC05E03	POWER CORD	A5	SJP2249-1	OUTPUT CORD
(EX, EH, EG)			A6	SPB1152T	AM ANTENNA
(E1)			A7	SQF13194	INSTRUCTION MANUAL
A1	Δ SJA163	POWER CORD	(EX, EH)		
(XL)			A7	SQF13195	INSTRUCTION MANUAL
A1	Δ SJA188	POWER CORD	(EG)		
(XA, PA, PE)			A7	SQF13196	INSTRUCTION MANUAL
A2	Δ RJP120ZBS-H	AC PLUG ADAPTOR	(PA, PE)		
(XA, PA, PE)			A7	SQF13197	INSTRUCTION MANUAL
A3	SSA269M	FM ANTENNA	(XA)		
			A7	SQF13198	INSTRUCTION MANUAL
			(XL)		
			A7	SQF13371	INSTRUCTION MANUAL
			(E1)		

ACCESSORIES

- AC power supply cord 1

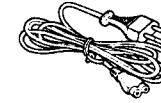

([EX, EH, EG, E1].....SFDAC05E03
 [XL].....SJA163
 [XA, PA, PE].....SJA188)

- Stereo connection cable 1
 (SJP2249-1)



- FM indoor antenna 1

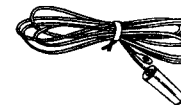

([EX, EH, EG, E1].....SSA270M
 [XL, XA, PA, PE].....SSA269M)

- AM loop antenna 1
 (SPB1152T)

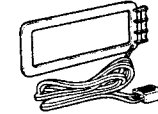

- AM antenna holders 2
 (SMA233-1M) (SMA231M)

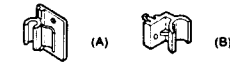

- Screws 2
 (XTN3+10AFZ)

